

Formation of particle clusters from rotating particle chains

D.Kappe^{1,*} and A.Hütten¹

¹Thin Films and the Physics of Nanostructures, Bielefeld University, PB 100131, 33501 Bielefeld, Germany

*corresponding author, electronic address: dkappe@physik.uni-bielefeld.de

Superparamagnetic particles do only show a magnetization, as long as an external magnetic field is applied. In a homogenous magnetic field, the particles only interact with each other. This interaction leads to chains of particles (see Figures 3a,b) [1]. If the field begins to rotate slowly, the chains will begin to rotate. Dissolved in a fluid, like water, the chains break apart when higher rotational frequencies are used. Depending on particle concentration, rotation frequency and the applied field's strength, the particles will form highly ordered structures (see Figures 3d,4) [2]. There are a few theoretical models for the formation and breaking of particle chains like [3], but the formation of particle clusters at high rotation frequencies is, to our knowledge, not been modelled before. Therefore, a COMSOL Multiphysics® model is presented to study their formation and hopefully improve the processes involved.

The demagnetization fields of the particles are assumed to be similar to that of a homogeneously magnetized ball. As this is inhomogeneous, other particles are subject to a force of $F = \mu_0 \mu_r \vec{m} \cdot (\nabla H_{tot})$. The magnetic moments \vec{m} of the particles are approximated to be aligned with the external field \vec{H}_{ext} and equal to $\vec{m} = V_{part} \pi \chi \vec{H}_{ext}$ with the particle volume V and the particle's magnetic susceptibility χ . Taking everything into account the magnetic force is [3]

$$\vec{F}_m = \frac{3\mu_0 m_i m_j}{4\pi r_{ij}^4} [(1 - 5(\hat{m} \cdot \hat{r})^2)\hat{r} + 2(\hat{m} \cdot \hat{r})\hat{m}]$$

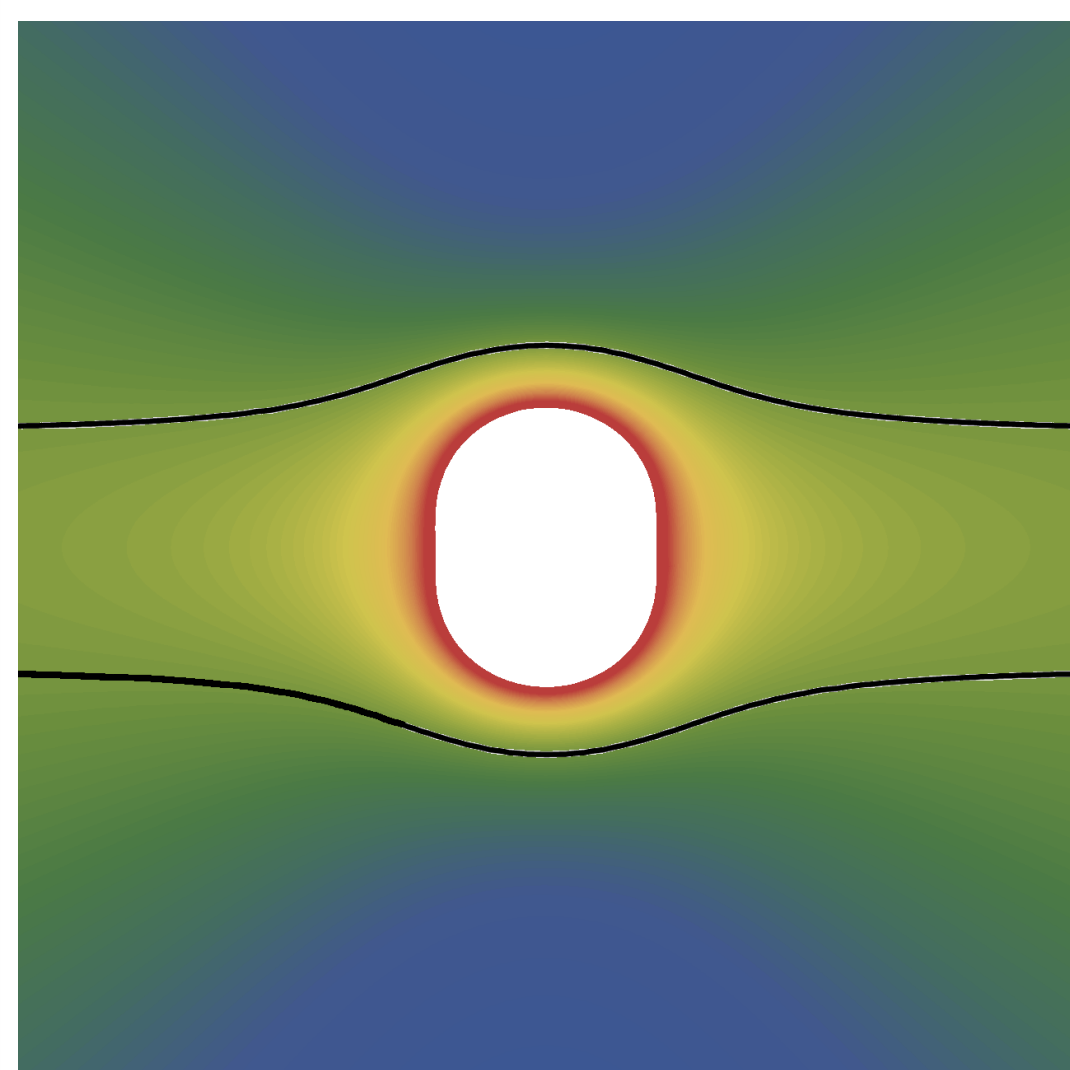

Figure 1
Plot of the force the particle in the center exerts on another particle, when both have a vertical magnetization. Blue marks a high drag, yellow a high push. The black line marks the point where no force towards the particle is exerted.

The counteracting force is the Stokes drag, which will cause the chains to break apart

$$\vec{F}_S = 6\pi \nu_{viscosity} R (\vec{v}_{fluid} - \vec{v}_{particle})$$

All other effects, like Brownian motion and the particles' influence on the fluid, are omitted to keep the model simple.

The COMSOL Multiphysics® interface "Particle Tracing for Fluid Flow" is used to handle the simulation. The "Drag Force" node, set to "Stokes", accounts for the Stokes Drag. The magnetic force is implemented as an "particle-particle interaction" node with an user-defined force. To prevent the particles from overlapping another "particle-particle interaction" node with a "Lennard-Jones" option is used, where the attracting part of the force is switched off manually. The standard solver settings are used and the time steps are set to 1ms. The computation is quite time consuming.

The particles are placed in a homogeneous, rotating magnetic field created by a rig of four Helmholtz coils (see Figure 2). The particles are observed with an optical microscope.

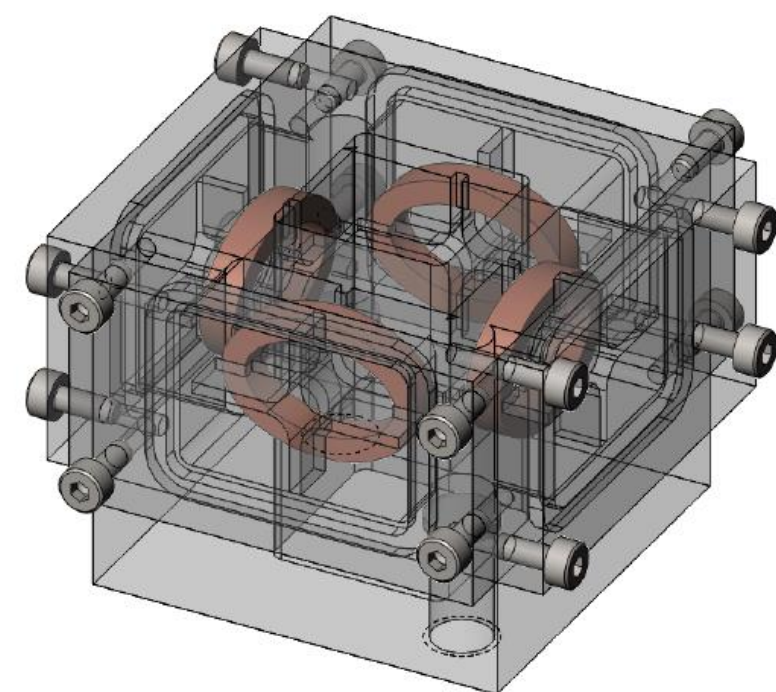

Figure 2
Rig of Helmholtz coils used to produce a homogeneous, rotating magnetic field [4]

An in-depth discussion of the experimental methods and results may be obtained in [4]. All Experiments were carried out with superparamagnetic particles with a size of up to a couple of micrometers.



Figure 3a
Microscopy image of particle chains slowly rotating

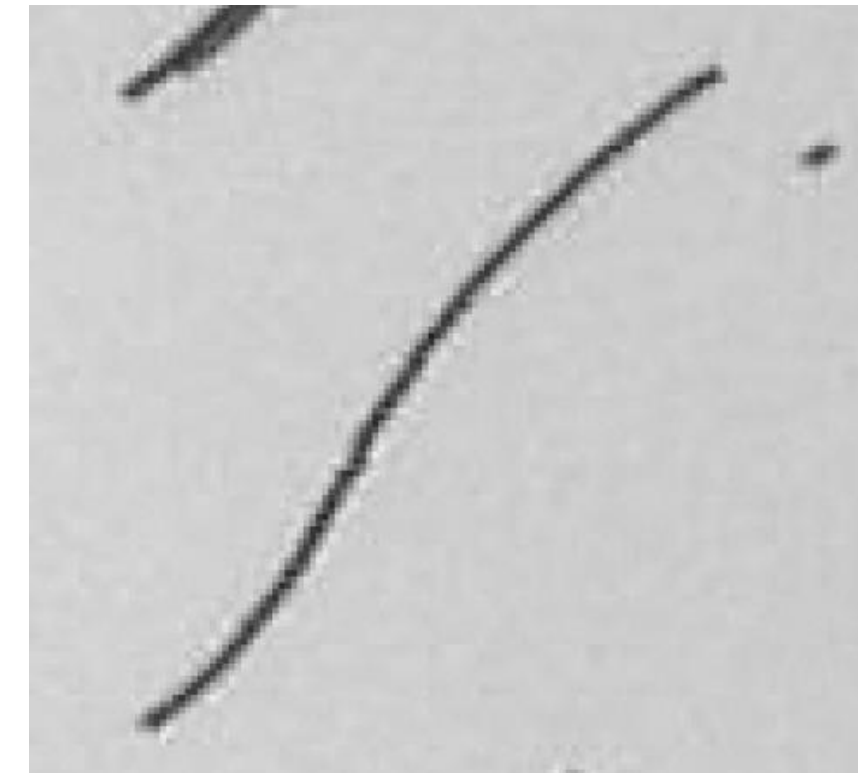

Figure 3a
Particle chain deformed into an s-shape due to Stokes drag



Figure 3c
Chain breaking apart as it is not able to follow the rotation of the magnetic field.

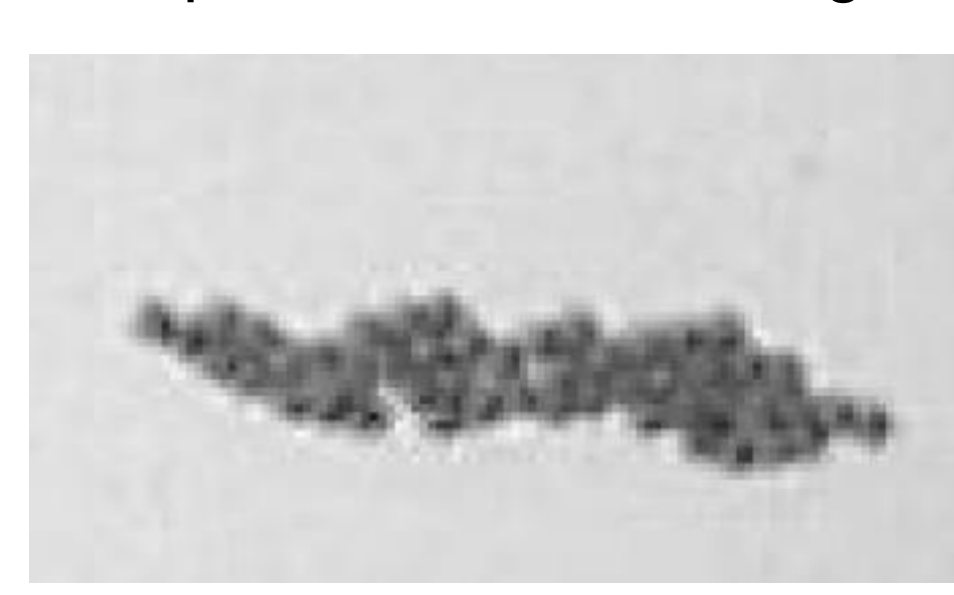

Figure 3d
Small cluster of particles in the process of forming

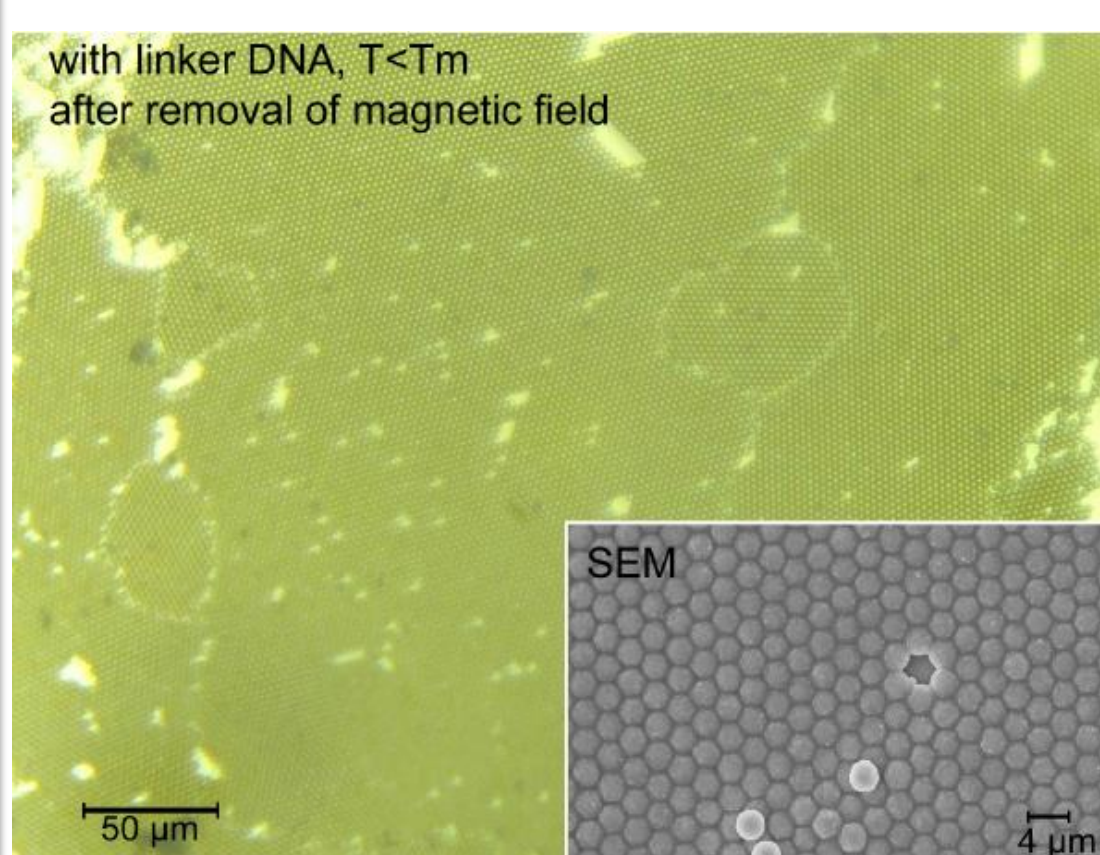

Figure 4
Particle cluster stabilized with linker DNA, to allow storage without applied fields. The inset shows a SEM (scanning electron microscopy) image of the highly ordered cluster.

The first simulation was carried out with more or less randomly chosen parameters, to check for the behavior observed in the experiments.

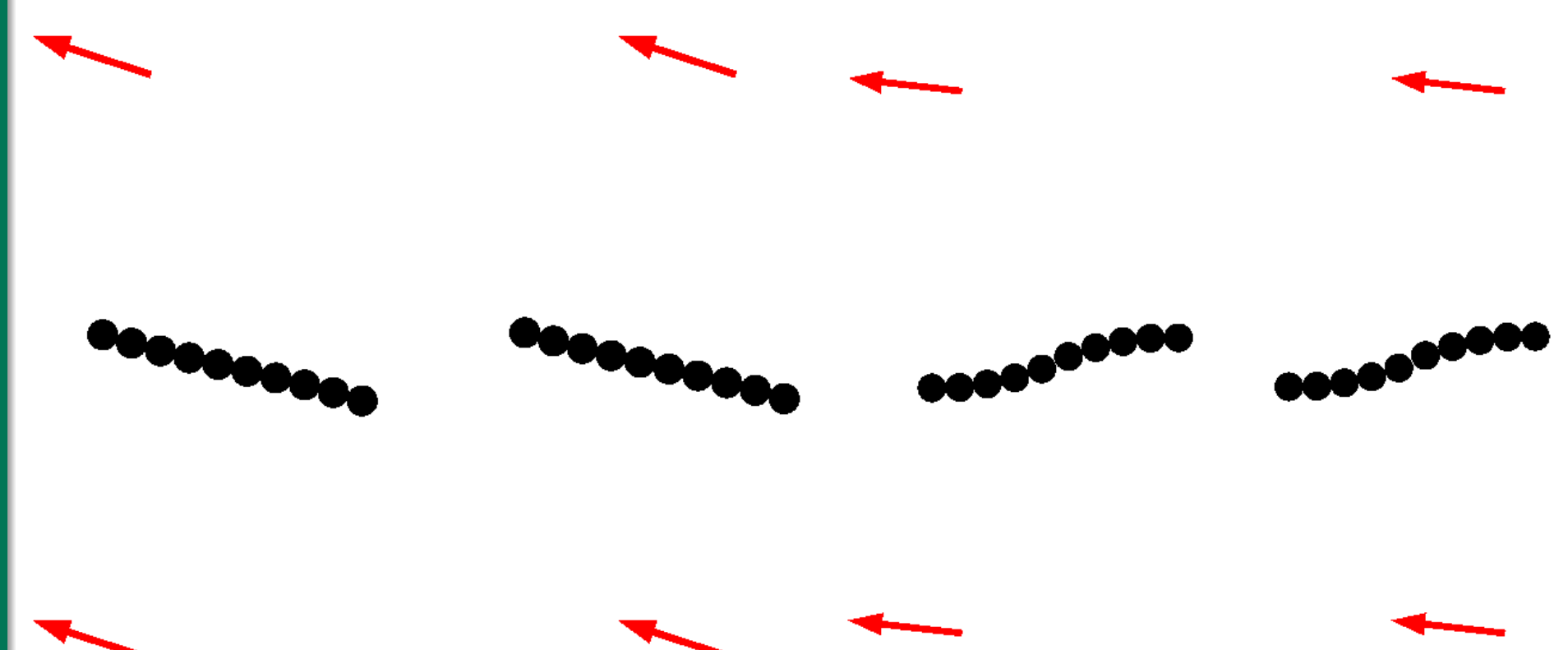

Figure 5a
Two particle chains slowly rotating. The magnetic field's orientation is indicated by the red arrows

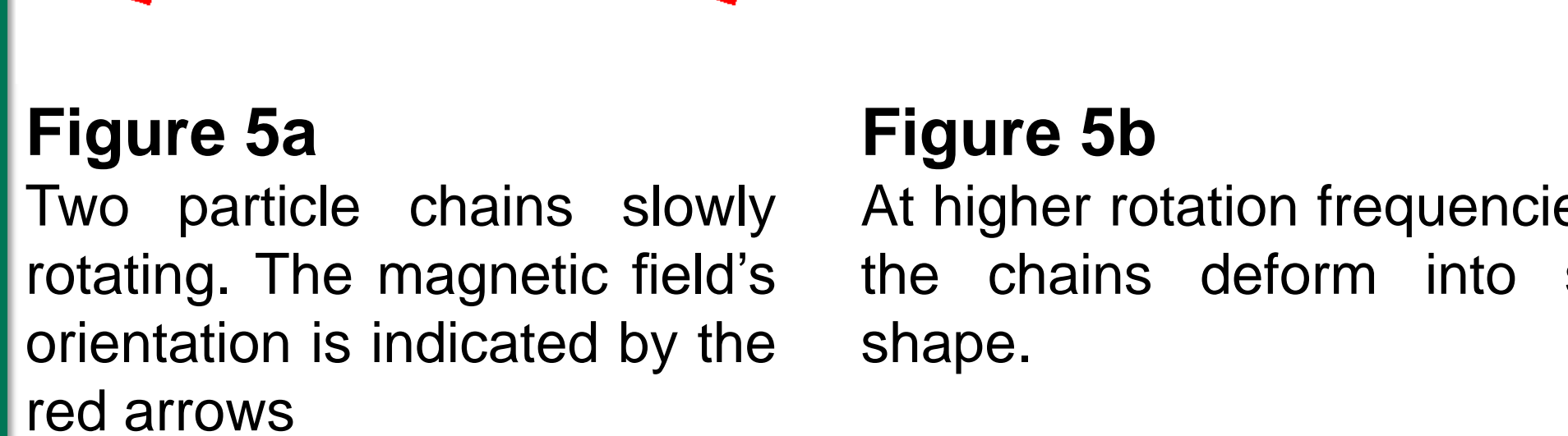

Figure 5b
At higher rotation frequencies the chains deform into an s-shape.

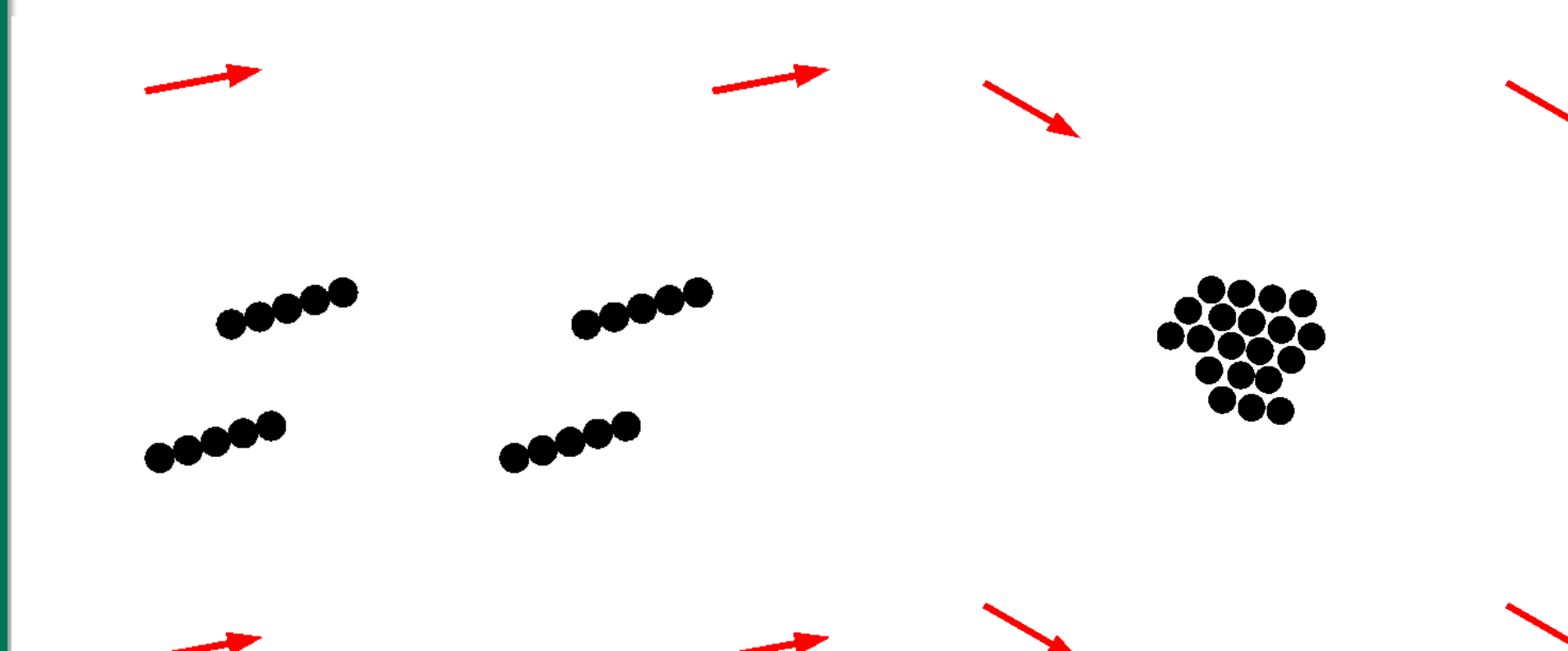

Figure 5c
The particles break apart into smaller chains, which are again able to follow the field's rotation

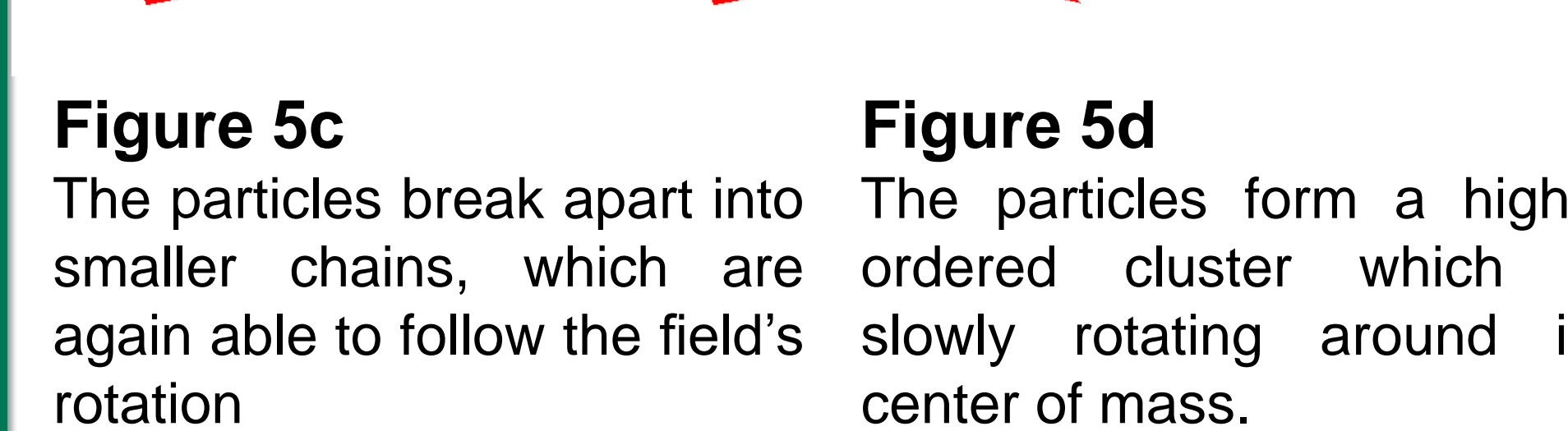

Figure 5d
The particles form a highly ordered cluster which is slowly rotating around its center of mass.

The Figures 5a-d show that a behavior similar to the experiment can be achieved with the model used.

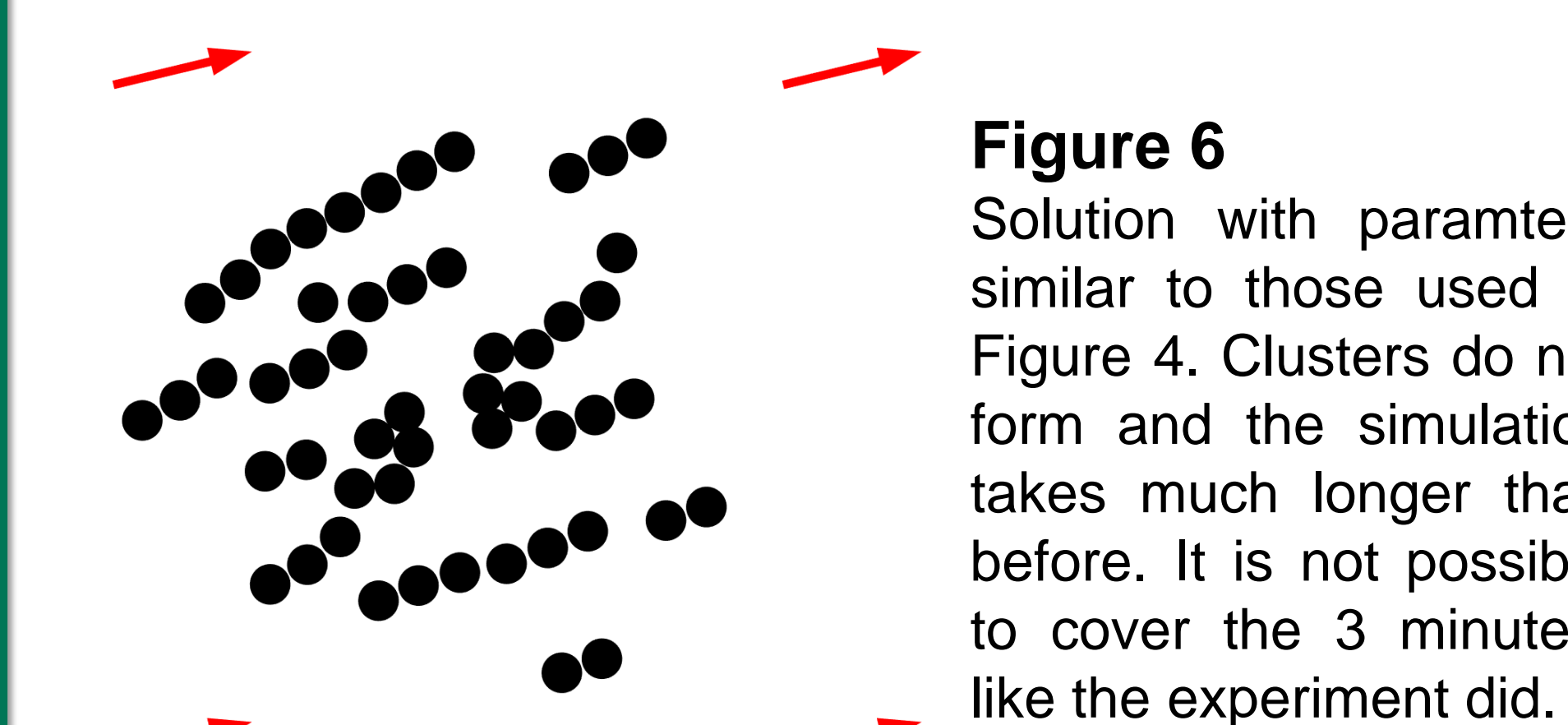

Figure 6
Solution with parameters similar to those used in Figure 4. Clusters do not form and the simulation takes much longer than before. It is not possible to cover the 3 minutes, like the experiment did.

Using parameters similar to the experiment, the particles do not form clusters anymore. This might be caused by the fact, that the full timespan of 3 minutes could not be covered. But Chances are that this is mainly caused by the approximations used.

[1] Promislow, Joanne HE, Alice P. Gast, and Marc Fermigier. "Aggregation kinetics of paramagnetic colloidal particles." The Journal of chemical physics 102.13 (1995): 5492-5498.

[2] Wittbracht, Frank, et al. "Rotating magnetic field assisted formation of highly ordered two-dimensional magnetic bead arrays." ICQNM 2011, The Fifth International Conference on Quantum, Nano and Micro Technologies. 2011.

[3] Gao, Y., et al. "Numerical and experimental study of a rotating magnetic particle chain in a viscous fluid." Physical Review E 86.4 (2012): 041503.

[4] Eickenberg, Bernhard. "Superparamagnetic beads as self-assembling matter for microfluidic applications." PhD Thesis Bielefeld University 2014.

Acknowledgments

The authors gratefully acknowledge the financial support of the "Forschergruppe Projekt 3" and "MoRiT S Projekt 1".