

# A 1-D Model of the 4 Bed Molecular Sieve of the Carbon Dioxide Removal Assembly

Robert Coker\*<sup>1</sup> and Jim Knox<sup>1</sup>

<sup>1</sup>Marshall Space Flight Center, NASA

\*Corresponding author: ES22, MSFC, Huntsville, AL 35812, robert.f.coker@nasa.gov

**Abstract:** Developments to improve system efficiency and reliability for water and carbon dioxide separation systems on crewed vehicles combine sub-scale systems testing and multi-physics simulations. This paper describes the development of COMSOL simulations in support of the Life Support Systems (LSS) project within NASA's Advanced Exploration Systems (AES) program. Specifically, we model the 4 Bed Molecular Sieve (4BMS) of the Carbon Dioxide Removal Assembly (CDRA) operating on the International Space Station (ISS).

**Keywords:** adsorption, flow, thermal transport, validation.

## 1. Introduction

The transport of the two concentrated sorbate species, water and carbon dioxide, in a carrier gas (air) was modeled as flow through four linked beds of sorbent pellets. The adsorption rates and pellet loading were determined from solving a general form partial differential equation (PDE) based on Toth isotherms<sup>1</sup>. The heat transfer in and between the gas, the porous media, the solid housing, and the can insulation was modeled as well. The mass fractions exiting an upstream bed were used as inlet boundary conditions for the next bed. A heater-assisted vacuum desorption model was developed for the carbon dioxide beds. Due to the complexity of the overall model, the use of COMSOL in 2-D has proven unsuccessful, so we have developed a pseudo-1-D model which represents essentially the same physics.

COMSOL Multiphysics models have favorably matched temperature and concentration data for a range of inlet vapor pressures, initial conditions, and flow rates for individual sorbent/sorbate pairs in sub-system tests<sup>2</sup>. Using these results for calibration of the full 4BMS CDRA system, we have applied the model to data sets from the CDRA Version 4 engineering unit test bed (CDRA4-EU).

The need for optimized atmosphere revitalization systems is necessitated by the aggressive new missions planned by NASA. Innovative approaches to new system development are required. This paper presents such an approach for the AES LSS project, where testing is supplemented with modeling and simulation to reduce costs and optimize hardware designs. The application of the COMSOL model in 1-D shows promise in predictively modeling the behavior of the ISS CDRA 4BMS and similar systems<sup>1,2,3</sup>. These modeling and simulation efforts are expected to provide design guidance, system optimization, and troubleshooting capabilities for atmosphere revitalization systems being considered for use in future exploration vehicles. This predictive simulation capability also provides a powerful tool for virtual troubleshooting of present flight hardware.

## 2. The CDRA 4BMS System

This paper discusses predictive modeling results using COMSOL's Multiphysics code for the entire CDRA 4BMS system. Fig. 1 illustrates the operation of the ISS CDRA 4BMS. Cabin air is sent through a desiccant bed, where water vapor is adsorbed. Then a cooler and blower pre-condition the dry air and send it through a sorbent bed where CO<sub>2</sub> is removed. The dry and (nominally) CO<sub>2</sub>-free air then goes through the second (desorbing) desiccant bed, where water vapor is added back to the air stream. This is then returned to the cabin. Meanwhile, the second sorbent bed has one end closed off and is heated, which releases the CO<sub>2</sub> from the bed. After a short (~10 min) 'air save' mode that recovers the bulk of the air trapped in the sorbent bed (while not desorbing significant CO<sub>2</sub> since the bed is still fairly cool), the bed is then vented to space. Such a sequence is known as a 'half-cycle' (HC) and is typically 155 minutes long. On the next HC, the valves are switched so that the two adsorbing beds become desorbing and vice versa.

### 3. 1-D Full System Modeling Approach

Adsorption in packed fixed beds of pelletized sorbents is presently the primary means of gas separation for atmosphere revitalization systems. For the bulk separation of CO<sub>2</sub> and H<sub>2</sub>O, temperature changes due to the heat of adsorption are significant, requiring the simulation of the heat balance equations through the beds and the housing, as well as the equations for sorption processes and fluid flow. For columns with small tube diameter to pellet diameter ratios, flow channeling along the column wall can have a strong influence on overall performance. In non-cylindrical flow, the influence is great enough to

eventually necessitate the use of 3-D simulations. Here, 1-D models have proven accurate enough for predictively driven system design of the desiccant beds<sup>1,2,3</sup>.

However, the sorbent beds are not cylindrical and the heaters used to assist in CO<sub>2</sub> desorption make for a potentially complex multi-dimensional flow path. In practice though, it seems that the dry air flows fairly uniformly through the channels, so that, nonetheless, a 1-D approximation may be sufficient to capture the bulk behavior of the beds. At the present time, 3-D models or even 2-D axisymmetric models are prohibitive, so for a quick turn-around to guide the design of the next generation CDRA, 1-D models will be used.

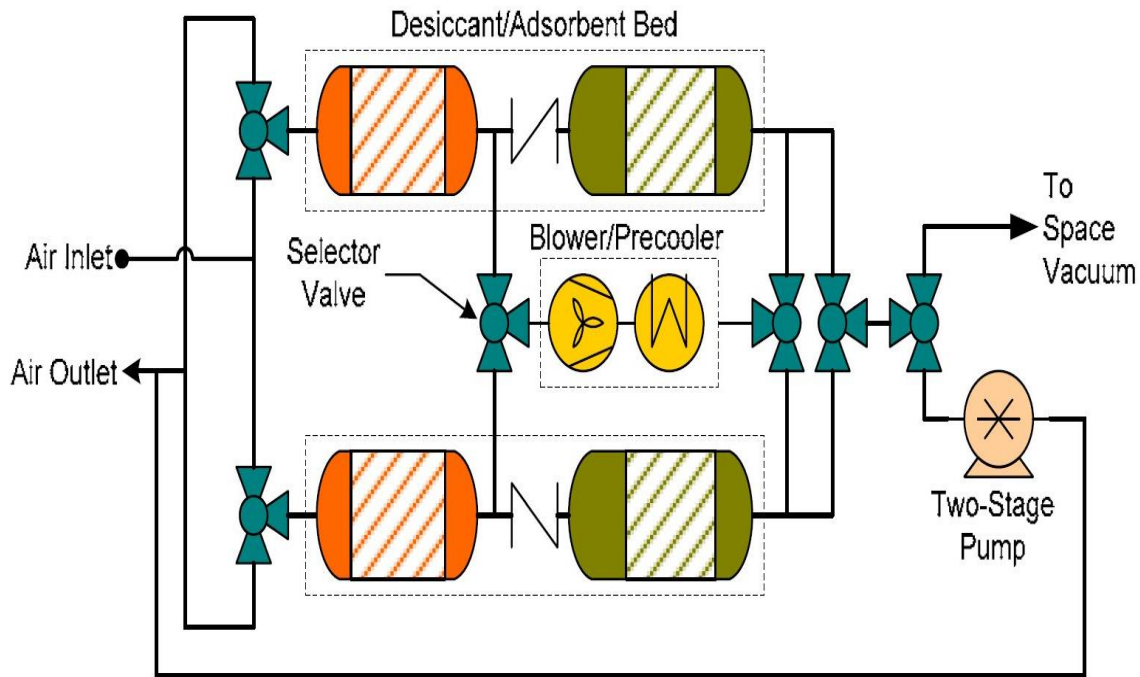

**Figure 1.** Schematic of the CDRA 4BMS. Air comes in from the cabin, has water vapor removed in a desiccant bed (orange), is cooled by the cooler (yellow), has CO<sub>2</sub> removed in a sorbent bed (green), gets water vapor put back in in the 2nd desiccant bed, then is returned to the cabin. Meanwhile, the 2nd sorbent bed is heated and evacuated to space.

The 4BMS is modeled as a fully coupled system, with the calculated mass fractions output as a function of time from one bed used as the inlet boundary condition for the next bed in the flow path. As discussed elsewhere, the 1-D COMSOL model is calibrated to test data from simple cy-

lic nodes, boundary conditions, and solver settings. Within each of these domains, the temperature of the sorbent, gas, can, and surrounding insulation are determined through separate heat transfer nodes. Domain PDE nodes are used to solve for the local pellet loading. Only the glass

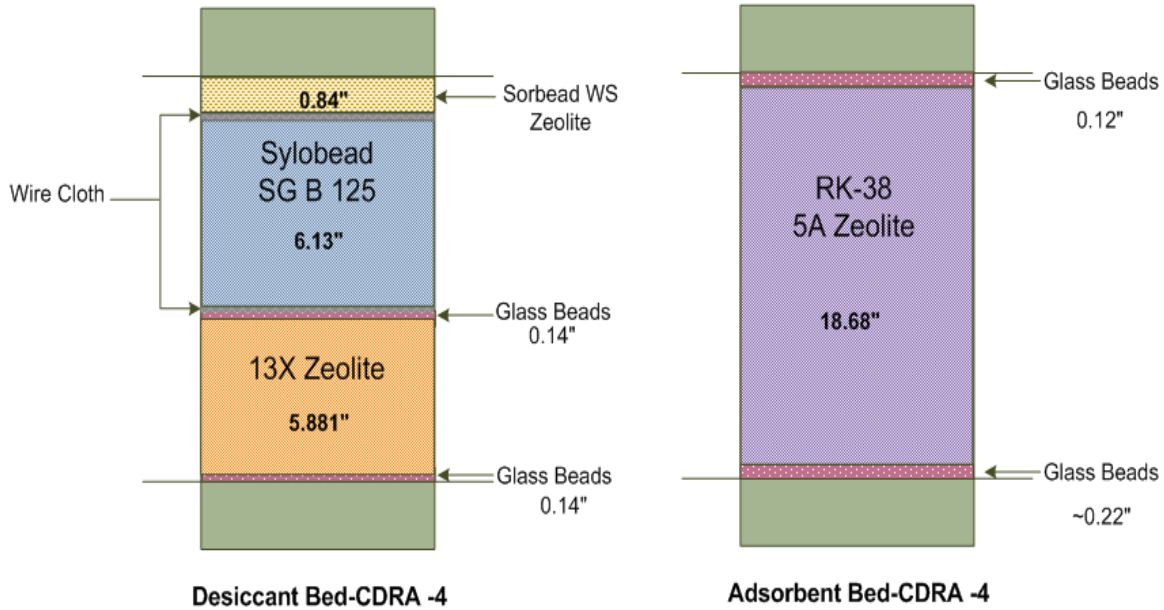

**Figure 2.** Idealized schematic of 4BMS model. Only the glass beads (red) and sorbents (orange, yellow, blue, and purple) are modeled. The inlet and outlet regions (green) and thin wire cloths (grey) are not modeled.

lindrical tests<sup>3</sup>. Thus, there are no knobs to turn and the model should be purely predictive.

However, the CDRA 4BMS uses heater-assisted vacuum desorption to desorb the CO<sub>2</sub> sorbent bed, so the Cylindrical Breakthrough Test (CBT) validation experiments are not applicable to the desorbing CO<sub>2</sub> bed. Some physics terms that could be neglected in higher pressure systems needed to be included for this work<sup>1</sup>. Since the sorbent bed channels are a small number of pellet diameters in size, the effective porosity due to wall channeling will be higher in a 1-D model than the equivalent model for the desiccant beds.

1-D models were constructed using the transport of concentrated species, Darcy flow, and thermal transport COMSOL modules to solve for concentrations, pressures, and temperatures, respectively. Each one of the four beds is modeled as a separate domain with its own phys-

ical and sorbent-containing parts of the beds, as illustrated in Fig. 2, are modeled.

A separate constant porosity, the known density of the sorbent, the measured mean particle diameter of the sorbent pellets, and the corresponding permeability, heat capacity, and thermal conductivity, were used for each component of each bed. The glass bead layers are treated in the same way as the sorbent layers, but with zero adsorption and desorption capacity for H<sub>2</sub>O and CO<sub>2</sub>.

COMSOL does not have an explicit bang-bang heater capability, so a Global Equation node for each CO<sub>2</sub> sorbent bed was used. This uses the 'Previous Solution' capability introduced in COMSOL 5.0 to solve the following nested logic equation to determine if heater power should be applied:

$$S_{new} = \text{if}(T_h \geq T_{max}, 0, \text{if}(T_h \leq T_{min}, 1, S_{old})) \quad (1).$$

If  $S = 1$ , the heater is on; if  $S = 0$ , it is off.  $T_h$  is the model temperature at the location of the sensor used to control the heater. The minimum and maximum heater set-point temperatures are  $T_{min}=390^\circ\text{F}$  and  $T_{max}=400^\circ\text{F}$ , respectively. There are two heater strings each of 480W, with only the first being used during the 10 minutes of air save mode. However, 30% of this power is not included in the model to account for unmodelled thermal sinks and heater issues.

Unlike previous work<sup>4</sup> which focused exclusively on sorption of a single sorbate ( $\text{H}_2\text{O}$  or  $\text{CO}_2$ ), to model the full CDRA 4BMS, both sorbates must be included simultaneously. However, accurate binary Toth isotherms do not exist over the pressure and temperature range required here. To a first approximation, the  $\text{CO}_2$  sorbent beds do not ‘see’ any  $\text{H}_2\text{O}$ , so a single  $\text{CO}_2$  isotherm is all that is needed. Similarly, the silica gel (SG) in the desiccant beds will effectively ignore  $\text{CO}_2$ . Thus, the only sorbent that will sorb both sorbates is the 13X in the desiccant beds. The 13X will adsorb  $\text{CO}_2$  only if there is little or no  $\text{H}_2\text{O}$  present. To model this behavior, a linear scaling factor was applied to the calculated single  $\text{CO}_2$  isotherm equilibrium loading, such that normal  $\text{CO}_2$  loading occurs at 0  $\text{H}_2\text{O}$  loading and no  $\text{CO}_2$  loading will occur if the  $\text{H}_2\text{O}$  loading is above  $q_{\max} = 28 \text{ mol/kg}$ ;  $\text{H}_2\text{O}$  loading occurs normally. Other than this, both the transport and sorption of the two sorbates are treated independently.

The solutions for temperature, concentration, and loading are the same as in Ref. 4, though the former two variables now use COMSOL modules rather than PDEs. In addition, the latter now uses a heat of adsorption that now depends on temperature and sorbate partial pressure. The total pressure is determined by solving Darcy’s law using that COMSOL module with a source term. Darcy’s law is a simplification, such that the second order Forscheimer drag term, the term with the gradient of the viscosity, and the momentum change due to pellet loading are dropped. In future work, these terms will be added back in if deemed significant.

The effluent mass fractions of  $\text{CO}_2$  and  $\text{H}_2\text{O}$  from a bed are used as the input to the next downstream bed. Due to the blower and cooler, the influent pressure and temperature of the adsorbing sorbent bed are regulated and thus are very different from the effluent from the adsorbing desiccant bed; constant measured values are used for the adsorbing  $\text{CO}_2$  influent pressure and temperature. For the influent of the desorbing desiccant bed, an 8% thermal energy loss is applied to the sorbent bed effluent temperature to mimic transport losses between the beds. Further, a ramp over the 1<sup>st</sup> second of the time-dependent calculations was needed to slowly increase the influent temperature or the sudden rise in temperature at the desorbing desiccant influent would cause COMSOL to crash. A similar ramp was needed at the influent of the adsorbing  $\text{CO}_2$  bed as it rapidly cools from over  $400^\circ\text{F}$  to  $\sim 50^\circ\text{F}$ .

The Sorbead WS SG that serves as a guard bed against liquid water (see Fig. 2) has no  $\text{H}_2\text{O}$  loading calibration data from the CBT. Therefore a published cooperative multimolecular sorption (CMMS) model was used for the isotherm of that bed<sup>5</sup>. The porosity of the RK38 bed is significantly higher than the other beds due to the narrow square channels of the sorbent bed resulting in larger empty regions near the walls, so a modeled, rather than measured, value for a similar 5A zeolite, G522, is used. Further, the porosity of the glass and RK38 beds are increased by another 15% to reflect the increased channeling in the sorbent bed being dominant in the 1-D model; this choice was arbitrary. Also, the thermal conductivity and heat capacity of the pellets in the sorbent beds were scaled to account for the thermal mass of the aluminum fins which contain the sorbent bed heaters. Although the mass transfer coefficient used in the linear driving force (LDF) model is a ‘free parameter’, it is not expected to be sensitive to different test conditions, such as flow rates, vapor pressure, or temperatures. Thus, it is not adjusted in the work presented here. In fact, all model input parameters are determined from the CBT or other tests or models, so that the work presented here is entirely predictive of the CDRA 4BMS behavior.

Some required inputs, such as total sorbent mass, degree of thermal insulation, and pressure drops across the beds, are not known for the ISS CDRA 4BMS ground test that is used here for validation. The same heat transfer coefficient of 5 W/m<sup>2</sup>/K was used from the can to the insulation and the insulation to the air; precise values do not have much impact since the thermal ‘choke point’ is the insulation. The pressure drops are only needed for the model initial conditions, so reasonable guesses were made and iterated upon for quicker convergence. The mass transfer of CO<sub>2</sub> on 13X is not well known; although this will be addressed in future work, here it is assumed it behaves as on 5A. The permeability and convective heat transfer coefficients were derived from empirical relationships. However, the heat transfer coefficient relationships for packed beds are not valid at low pressures, so for the desorbing sorbent bed, a scale factor that goes as  $\sqrt{(1 \text{ atm}/P)}$  was applied to the calculated coefficient; this reflects the increased importance of un-modeled thermal paths at low pressures. Some inputs may vary significantly over time and/or from test to test, so they are taken from the actual test being validated. The adsorbing desiccant bed inlet temperature and H<sub>2</sub>O partial pressure and the desorbing sorbent bed effluent pressure are time-dependent values taken from the tests. Flow rate, ambient temperature, system inlet CO<sub>2</sub> partial pressure, sorbent bed inlet temperature, and influent total pressures are constant values taken from the tests. Given these inputs, the COMSOL model should completely predict the behavior of the CDRA 4BMS, within the limits of the 1-D simplification and inherent accuracy of the LDF model. For faster runtime as well as increased numerical stability, the initial conditions for the bed loadings are set to be close to the expected final results. Run time convergence then takes from 3 to 9 HCs.

Even though the experimental measurements of gas temperature and H<sub>2</sub>O dew point are taken

upstream of the actual influent, with a valve and significant piping between the sensors and the bed, the data are used as-is in the COMSOL model as time-dependent inlet boundary conditions. The measured time-dependent total pressure during desorption of the sorbent bed is also used as a model boundary condition. At low pressures, the total pressure measurements are inaccurate, however, and thus they have been replaced with a Gaussian fit to the data; the non-monotonic nature of the ‘noise’ at low pressures in the original data caused COMSOL to crash, even using a floor pressure value. Similarly, the data sampling rate is not fast enough to capture the first ~30s of the pressure, so a data point equivalent to the adsorbing inlet pressure (~15 psi) has been added; cubic interpolation is assumed in COMSOL between points in time.

**Table 1.** CDRA-4EU Baseline Nominal Inputs

Half-cycle time	155 min
Inlet temperature	49°F
Inlet dewpoint	40°F
Inlet CO <sub>2</sub>	0.52%
Flow rate	20.4 SCFM
Air save	10 min

#### 4. COMSOL Results and Discussion

The COMSOL results for the predicted and experimentally measured sorbent bed temperatures and carbon dioxide partial pressures are shown Figures 3 and 4. The baseline test data discussed here were taken at MSFC on the CDRA-4EU. The nominal baseline operating conditions are given in Table 1. The experimental system converges fairly quickly; the data discussed here are taken from the 4<sup>th</sup> half-cycle of the test.



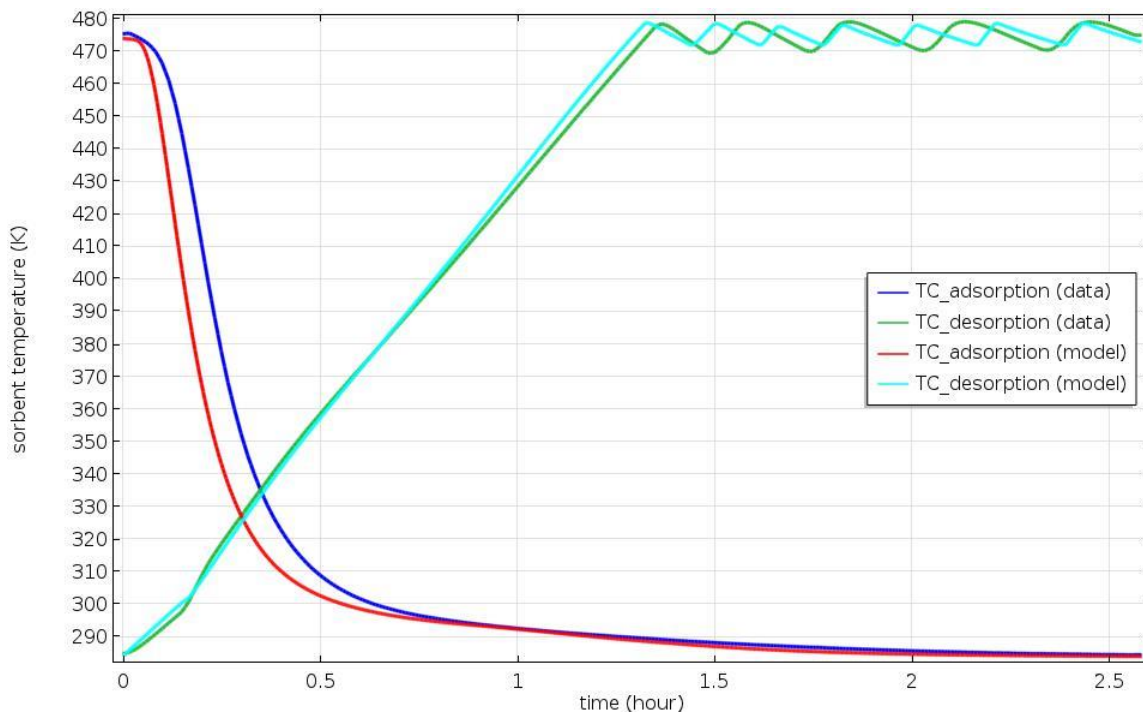

**Figure 3.** Temperatures at the heater TC locations in the sorbent beds.

The temperatures, for both the baseline CDRA-4EU dataset and the COMSOL model, at the axial location of the thermocouples (TCs) used to control the heaters in the sorbent bed are given in Fig. 3. It can be seen that the model cools during adsorption slightly too quickly (cf., the red curve to the dark blue curve). During desorption, the model matches the data fairly well, particularly since the 1-D model is calibrated to the larger and simpler cylindrical geometry of the CBT and includes the ‘fins’ in only the most ad hoc fashion.

Fig. 4 shows the carbon dioxide partial pressure at the desiccant bed influent and effluent. Note the baseline data only has CO<sub>2</sub> measurements at the CDRA 4BMS influent and effluent. The model matches the spike near the beginning of the HC due to the CO<sub>2</sub> being competitively driven off of the 13X in the desiccant bed; the related adsorption (and subsequent competitive desorption) of the CO<sub>2</sub> by the 13X during the first ~30 minutes of a HC can be seen in the model adsorbing effluent curve (light blue). The baseline data show partial breakthrough of the CO<sub>2</sub> at late times through the desiccant bed (green curve) which the model (purple curve) qualitatively captures. The small amount of CO<sub>2</sub>

that gets to the influent of the desorbing desiccant bed at the beginning of the HC (yellow curve) is due to the tiny amount of residual air trapped at the closed end of the desorbing sorbent bed. The rise at the end of the HC reflects the fact that the sorbent bed is fully breaking through. Thus, by the end of a HC, both the 5A and the 13X are nearly fully loaded with CO<sub>2</sub>. Although somewhat counter-intuitive, this is perfectly acceptable operation, since a full sorbent bed enables maximum efficiency in removal of the CO<sub>2</sub> during desorption. However, other system parameters (e.g. heater power) may not be optimum in this configuration. In the future, this COMSOL Virtual Laboratory will be applied to such optimization issues.

## 5. Conclusions

The 1-D COMSOL model shows great promise in predictively modeling the CDRA 4BMS, even with some admittedly ad hoc approaches to the 1-D modeling of a very 3-D system. With some further validation against different CDRA-4EU datasets, it will be used as a virtual laboratory to explore optimization of the CDRA 4BMS

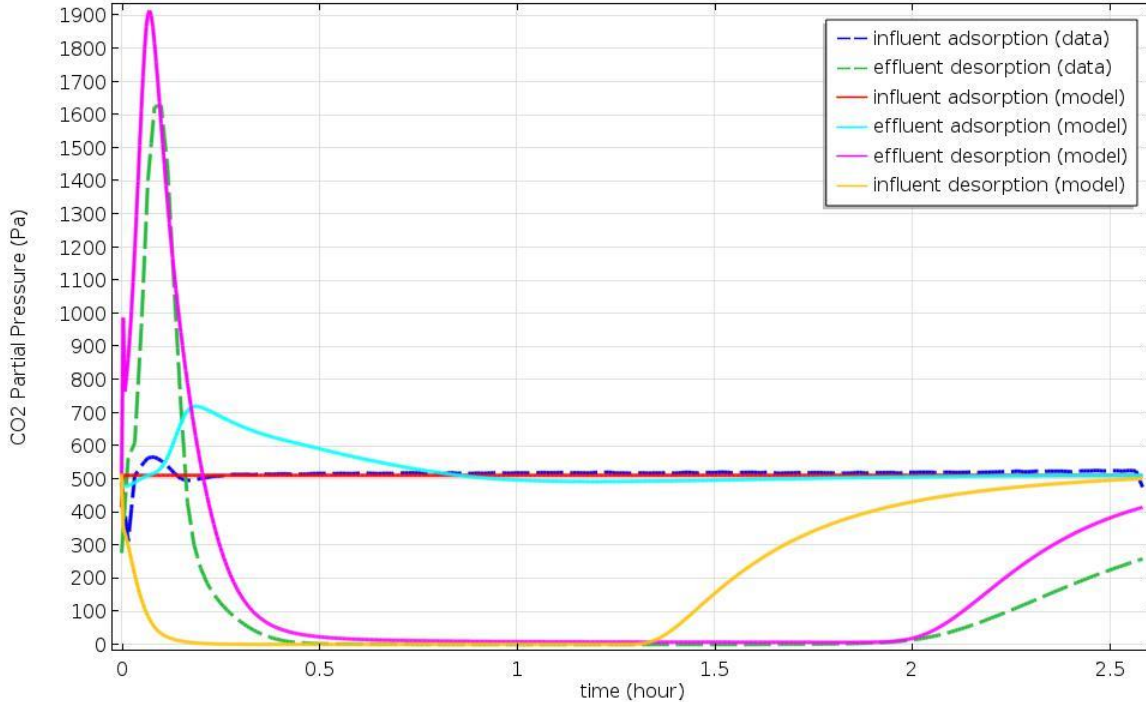

**Figure 4.** Partial pressure of carbon dioxide at the desiccant bed influent and effluent. Both the data (dashed green) and the model (purple) show some CO<sub>2</sub> breakthrough at the end of the HC. The model adsorption effluent (light blue curve) illustrates the competitive uptake and release of CO<sub>2</sub> by the 13X at the start of a HC.

sub-system on ISS. Clearly the actual system is not 1-D and further empirical work will be needed, particularly to model the narrow non-cylindrical channels of the sorbent beds. However, it has already been used, for example, to point out unexpected heat leaks in the sorbent beds and predict break-through behavior in the desiccant beds.

## 5. References

- <sup>1</sup>Coker, R., and Knox, J.C., "Full System Modeling and Validation of the Carbon Dioxide Removal Assembly", Boston COMSOL 2014 Conference, 2014.
- <sup>2</sup>Coker, R., Knox, J.C., Schunk, G., and Gomez, C., "Computer Simulation and Modeling of CO<sub>2</sub> Removal Systems for Exploration", *45<sup>th</sup> International Conference on Environmental Systems*, Seattle, ICES-2015-160, 2015.
- <sup>3</sup>Knox, J.C., et al., "Development of Carbon Dioxide Removal Systems for Advanced Exploration Systems 2014-2015", *45<sup>th</sup> International Conference on Environmental Systems*, Seattle, ICES-2015-177, 2015.
- <sup>4</sup>Coker, R., Knox, J.C., Gauto, H., and Gomez, C., "Full System Modeling and Validation of the Carbon

Dioxide Removal Assembly", *44<sup>th</sup> International Conference on Environmental Systems*, Tucson, ICES-2014-168, 2014.

<sup>5</sup>Dong, X.U., et. Al., "CO<sub>2</sub> Capture by Vacuum Swing Adsorption Using F200 and Sorbead WS as Protective Pre-layers", *Separation Science and Engineering*, **20**(5)849-855, 2012.