



Simulating Ear Canal Pressure

Occlusion Relief in Earphones With μValve Acoustic Vents

COMSOL
CONFERENCE
2024 BOSTON

October 3 Session

Presenter:

Michael Ricci

Sr. Director, Electroacoustic Engineering

Problem

The occlusion effect is an increase in loudness of our voice when the ear canal is sealed or occluded, often referred to as head-voice. Inserting hearing protection plugs, hearing aids, TWS earphones or In-Ear Monitors into our ears creates a seal, trapping voice sound energy in the ear canals causing the occlusion effect. This increase in vocalization is concentrated in the lower frequencies of the voice band. Other self-generated sounds such as chewing, swallowing, walking or running are also amplified when ear canals are blocked. Most consumers and musicians using occluded audio products turn up the volume to counteract their head-voice when taking calls or singing.

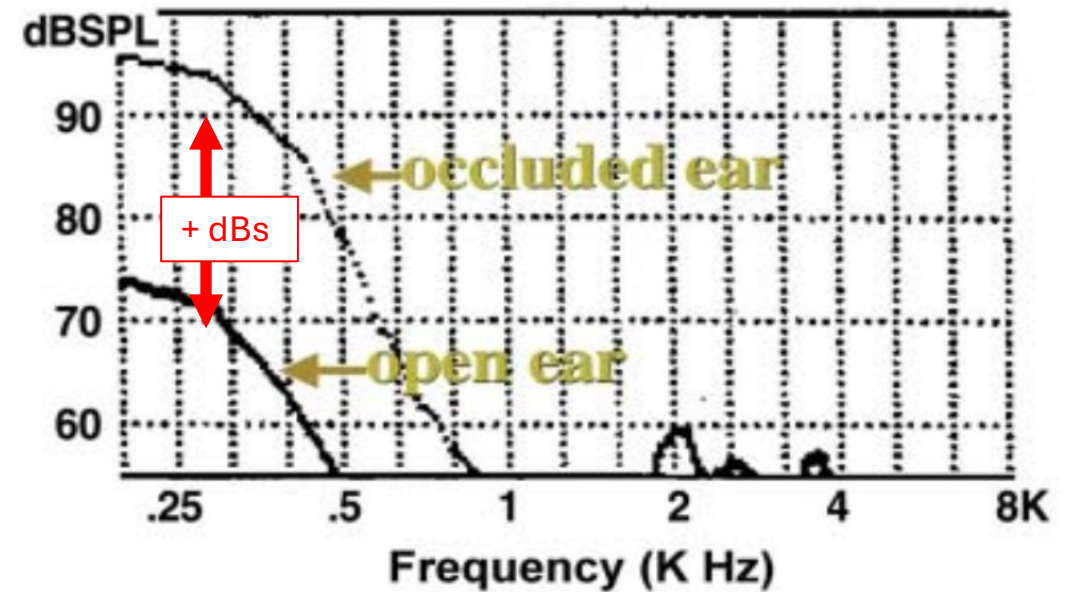
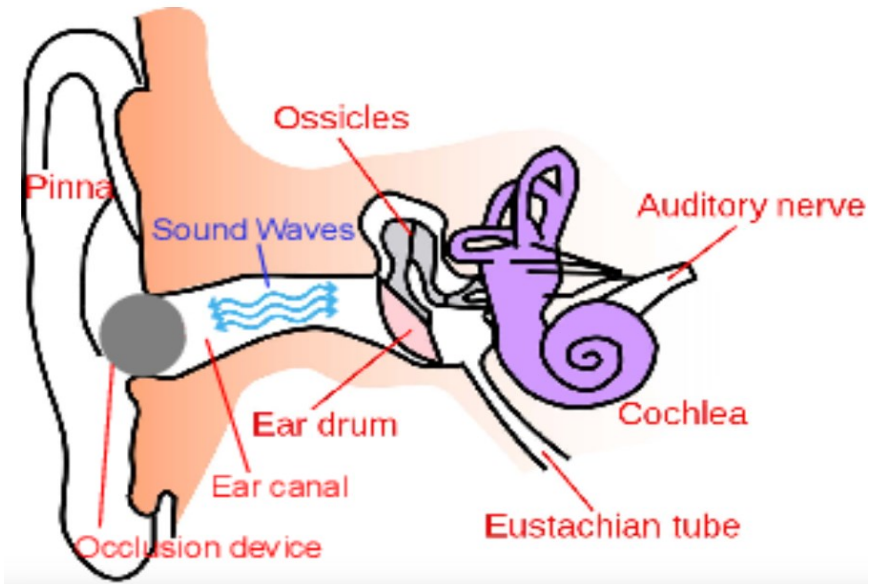
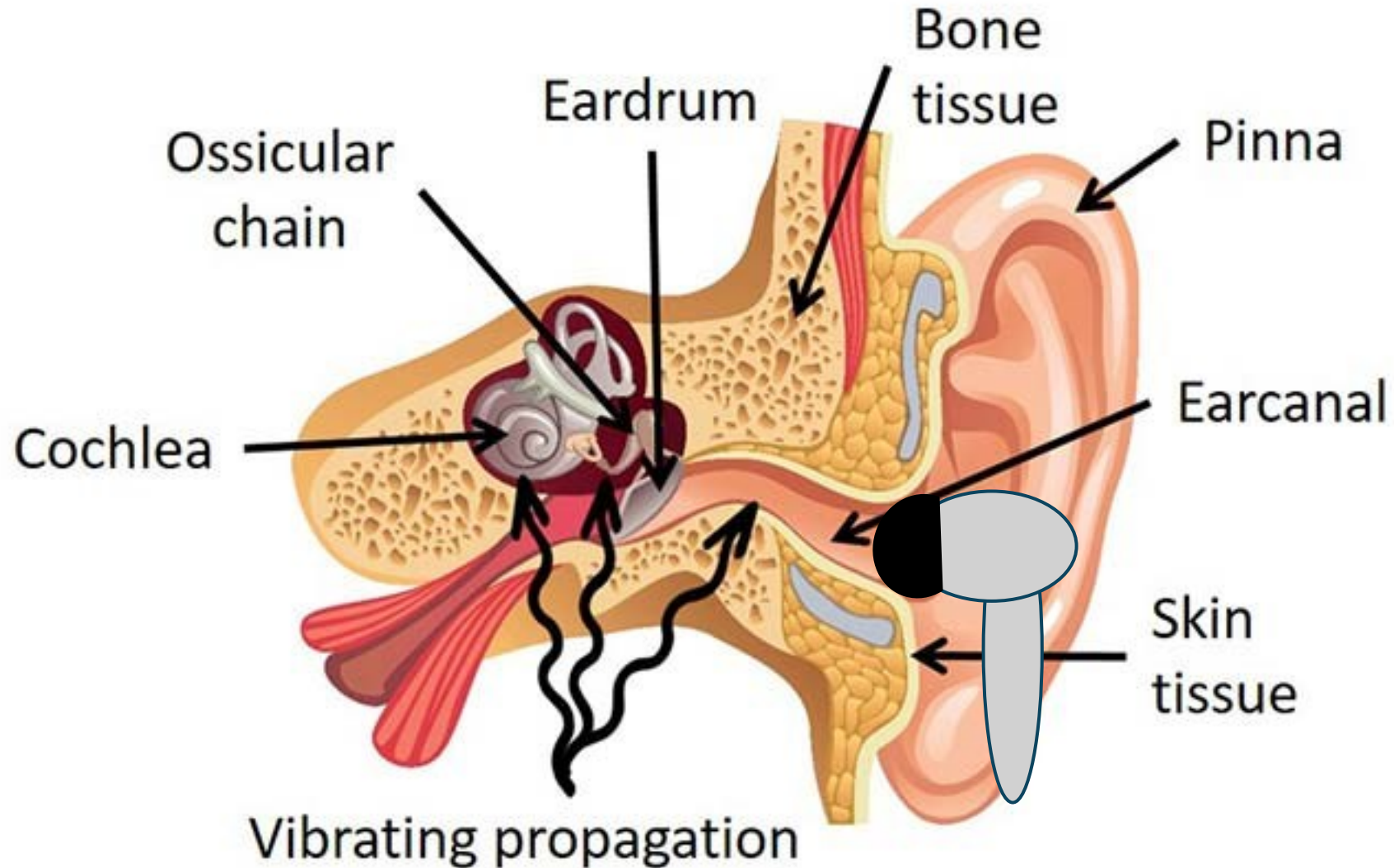

Figure 1. Real ear response of /i/ measured in an open-ear and an occluded ear condition.

Occlusion Effect – Auditory/Physiological Model



Occlusion Effect – Electroacoustic Model

(a) Electro-acoustical model of ear canal sound pressure caused by bone conducted sound

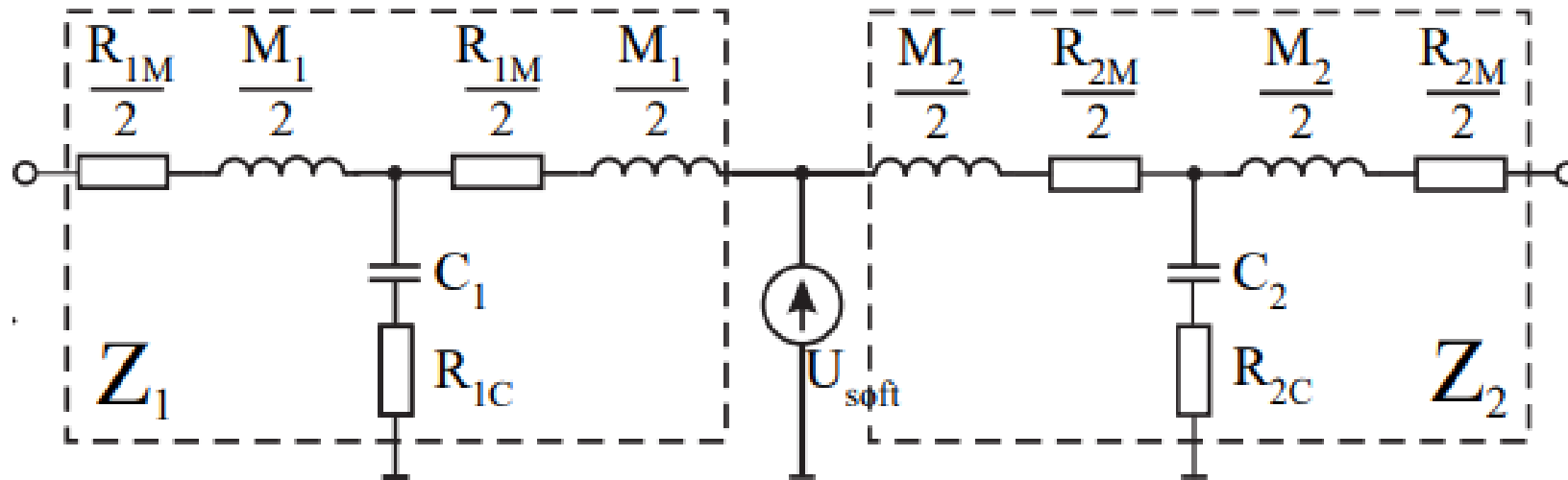
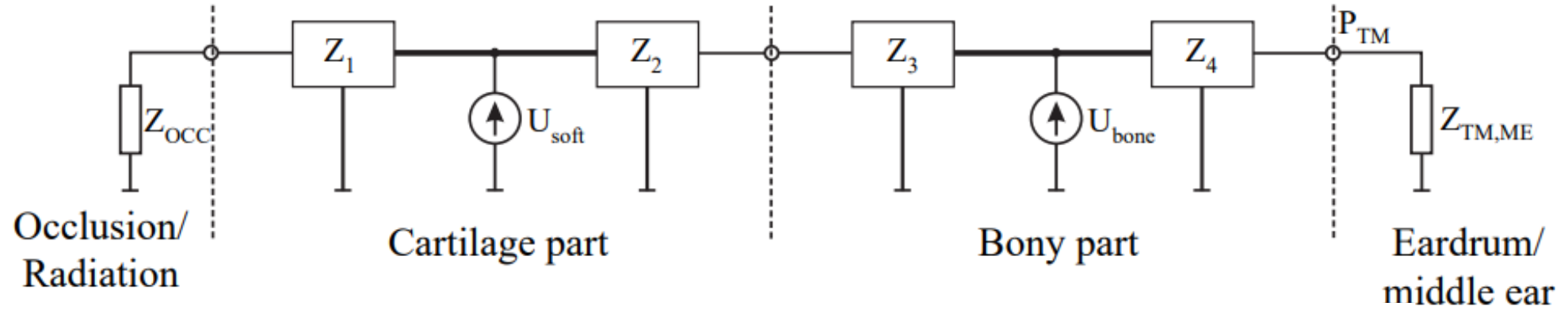

Current Hearing Aid And Consumer TWS

Some hearing aids use active cancellation with venting the occluded ear, which requires an audiologist prescription. Transparency mode in TWS earphones require additional processing reducing battery life, yet still provides no occlusion relief.

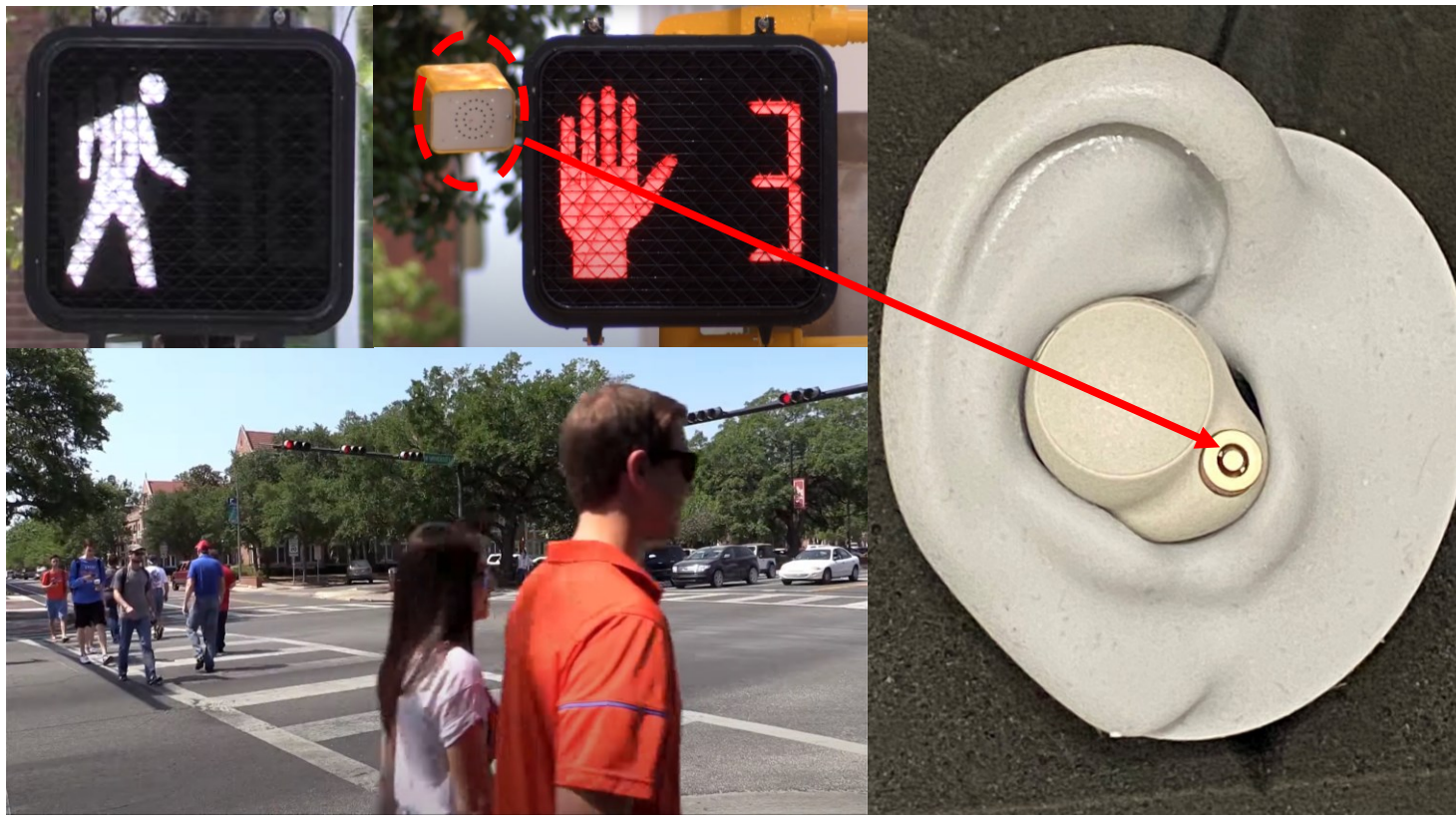
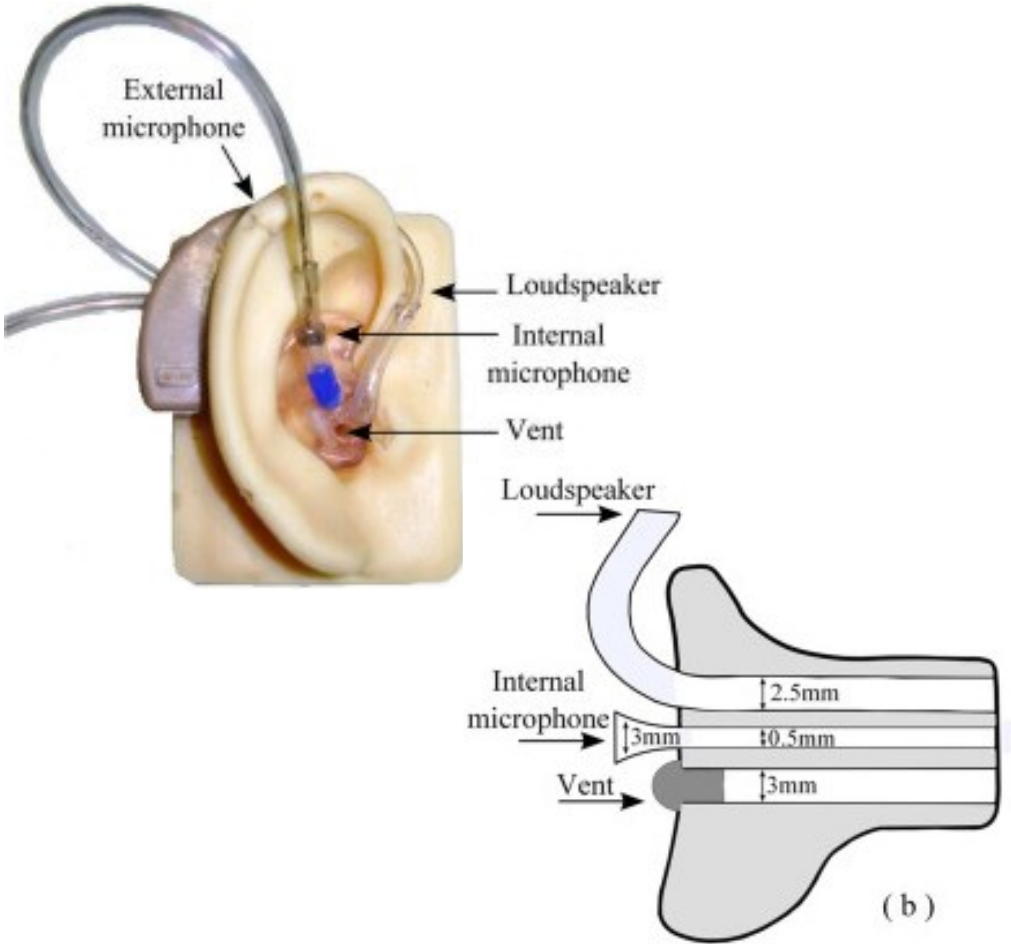

Modeling Acoustic Vents Using COMSOL Multiphysics

To model occlusion reduction, an LPM of a Piezo-MEMS acoustic vent was created. The Type 3 IEC 60318-4 711 coupler model (B&K Type 4147) available from the application library was used as the front volume acoustic load. The CAD import tool was used to build a mesh for the earphone geometries. Experiments were conducted with various pressure conditions in the ear canal related to the acoustic vents open, closed and comfort states in an occluded earphone device. Simulations were compared to physical test results of 3D printed earphone.

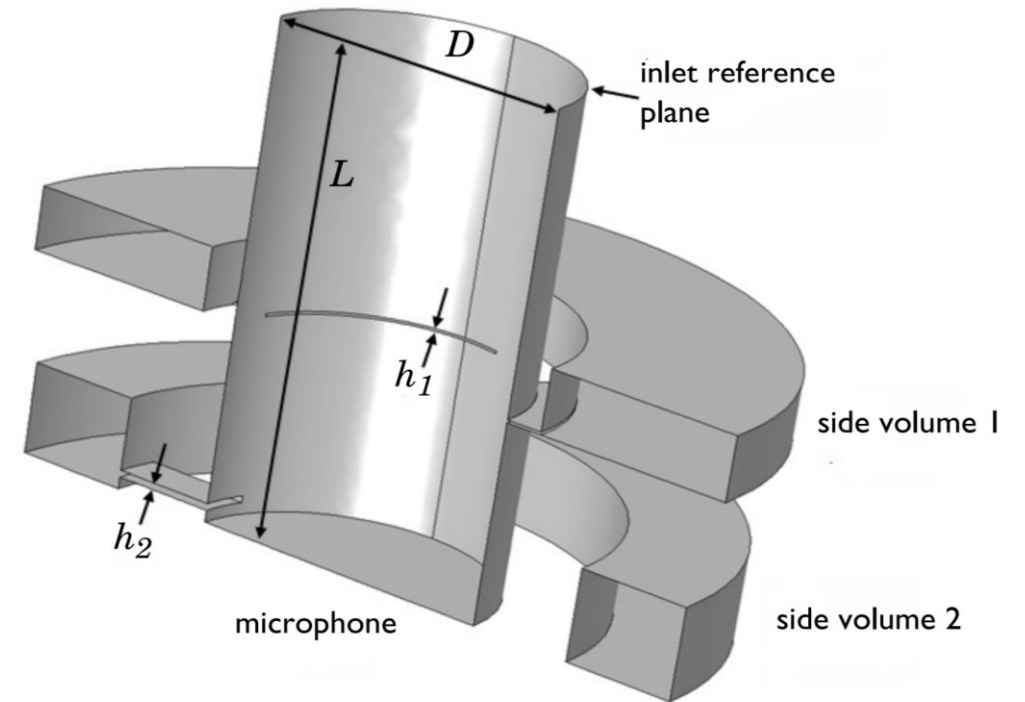
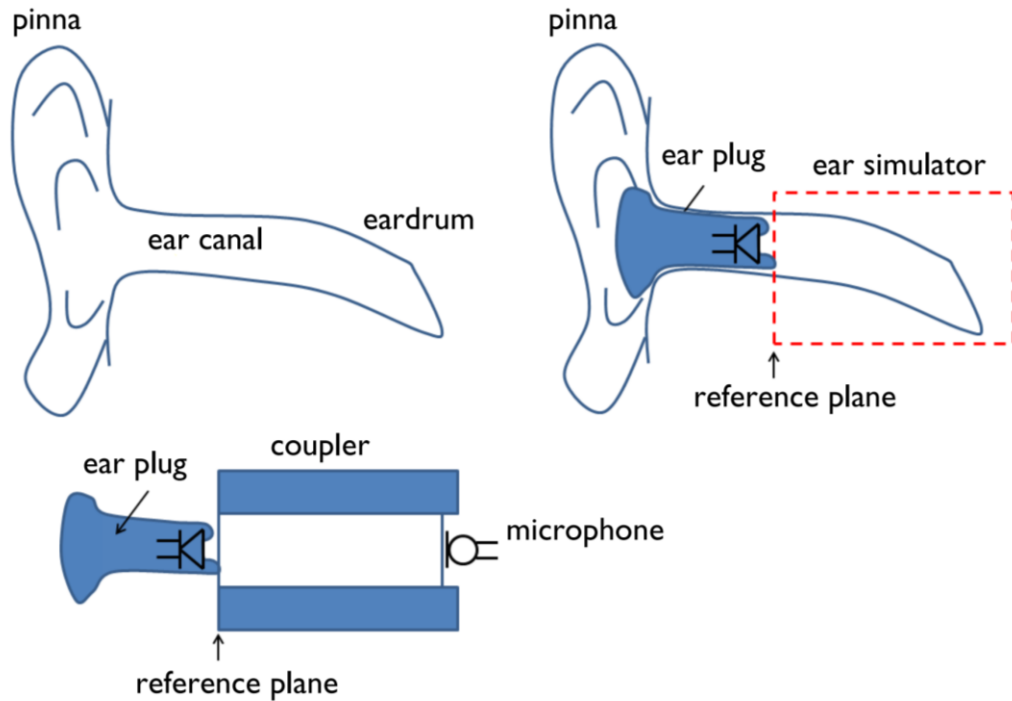
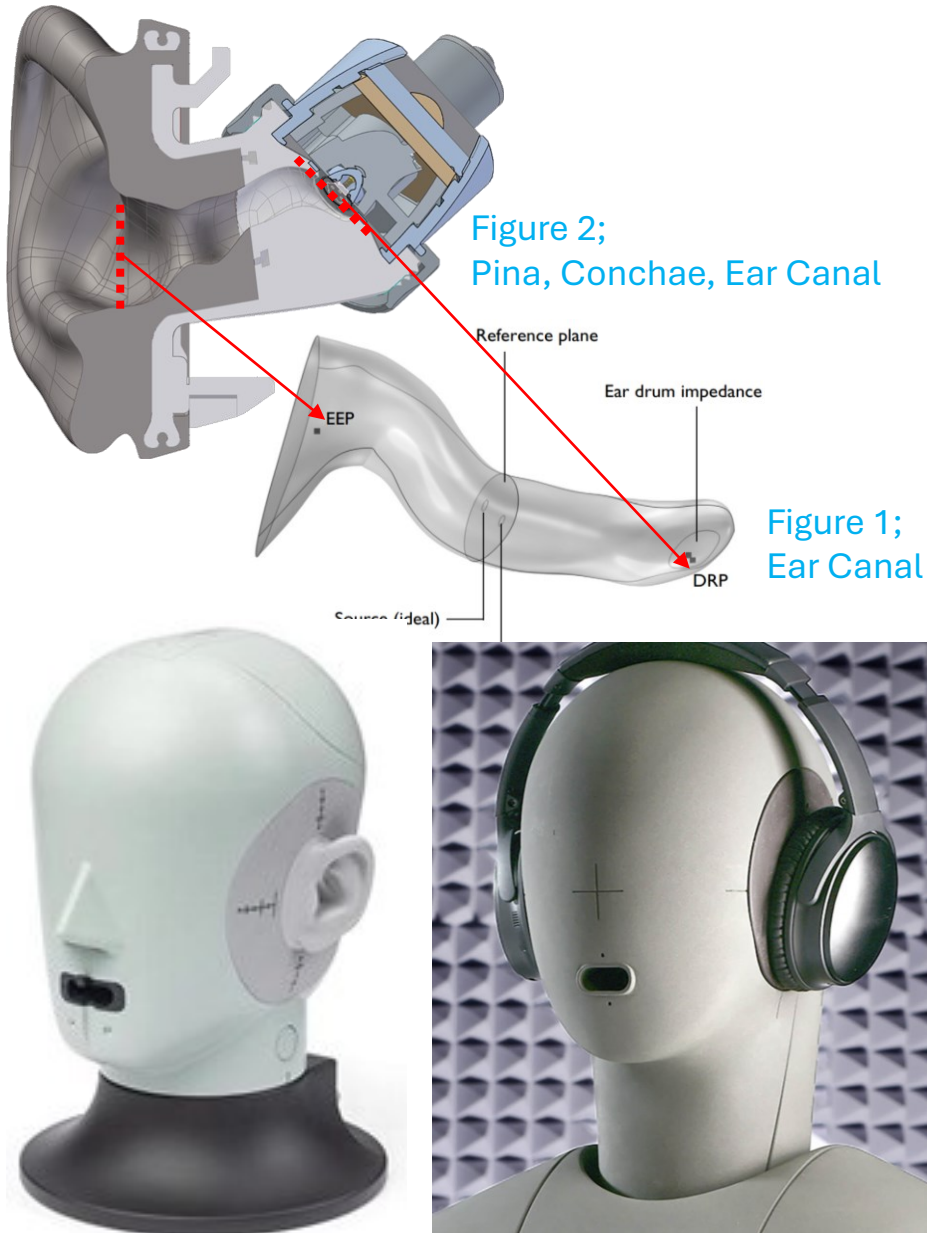

Figure 1: (upper left) sketch of the ear with pinna, ear canal, and eardrum, (upper right) ear canal occluded by an earplug with a loudspeaker, the occluded-ear canal is the part that the coupler is intended to model, (bottom) ear plug placed at the reference plane of the acoustic coupler including the location of the recording microphone.

Figure 2: Sketch of the geometry used in the model (cut in half due to symmetry). The main volume is a cylinder of length L and diameter D . The two side volumes are attached to the main volume via slender slits of height h_1 and h_2 .

Type 4.3 Ear Simulators – Accurate Acoustic Impedance < 20kHz



This model imports a geometry representation of the ear canal (Figure 1) as well as the combined pinna and ear canal (Figure 2) that is defined in the ITU-T P.57 standard, Ref. 1. To fulfill the acoustic requirements specified in the ITU-T P.57 standard, the eardrum impedance presented in Nielsen and Jensen, 2022 (Ref. 2) is imported as an interpolation function and used. Some details about the construction of the geometry are presented in Ref. 2.

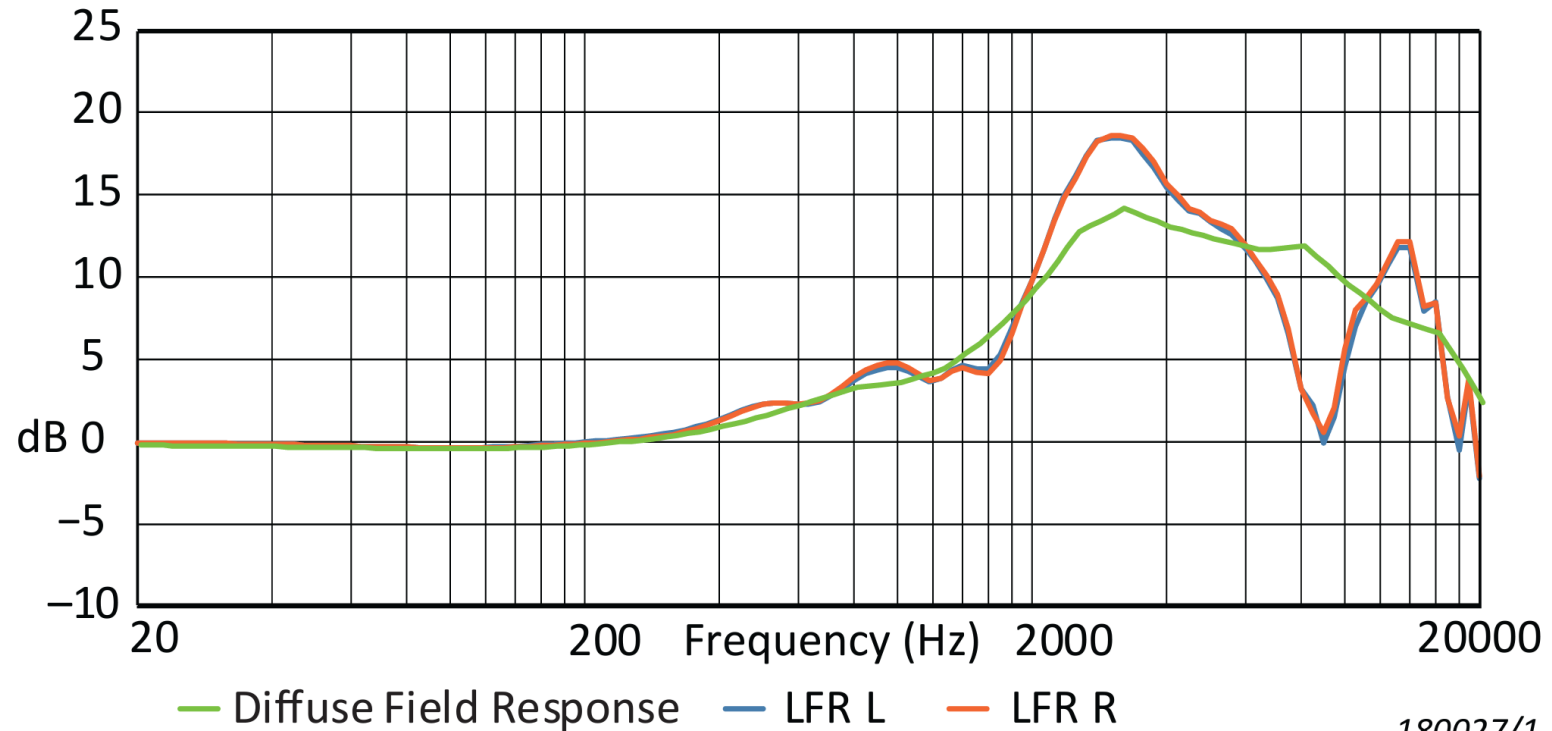

Type 3 711 Coupler vs. Type 4.3 Ear Simulator

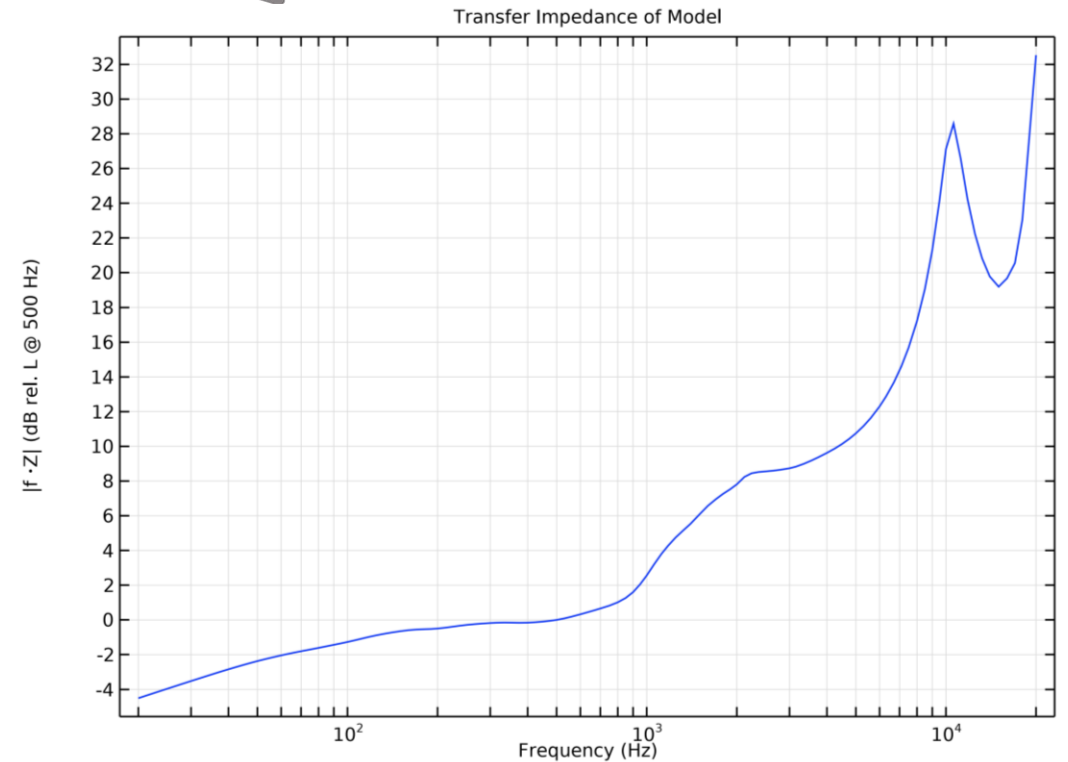
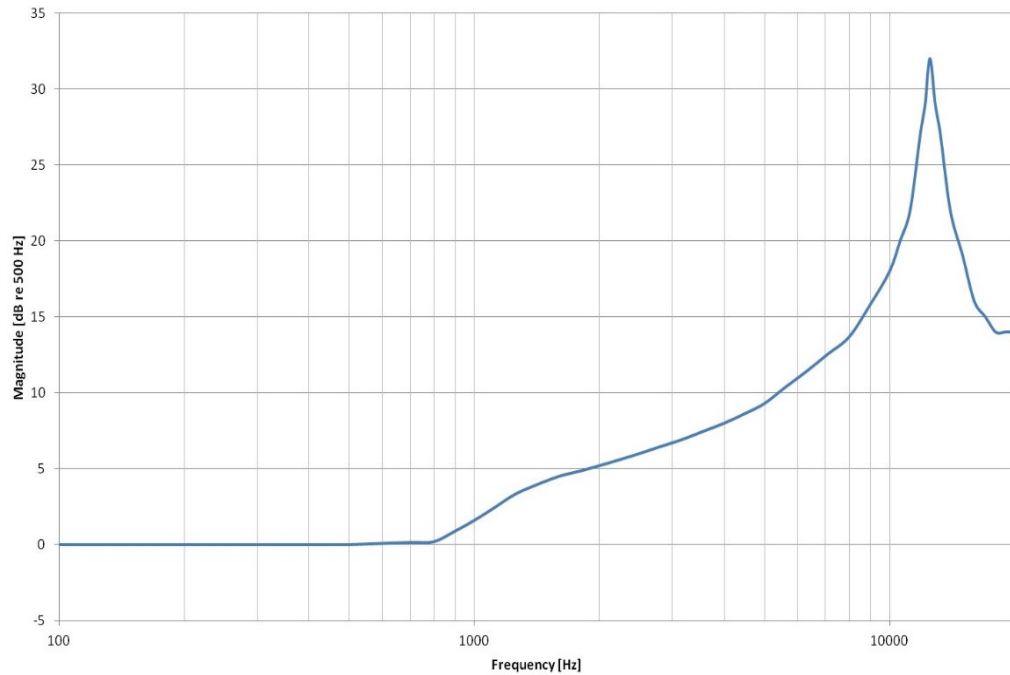
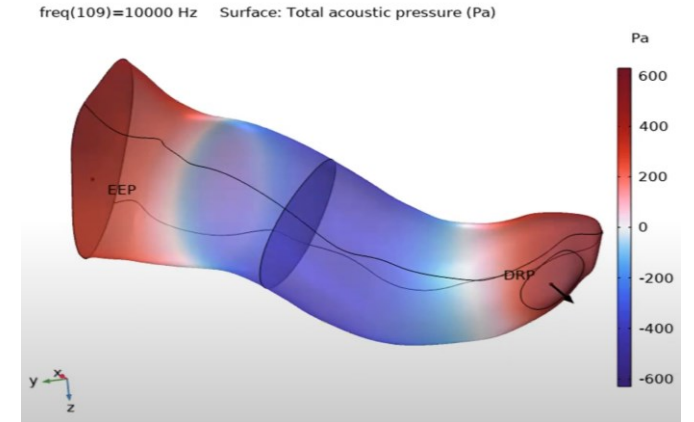
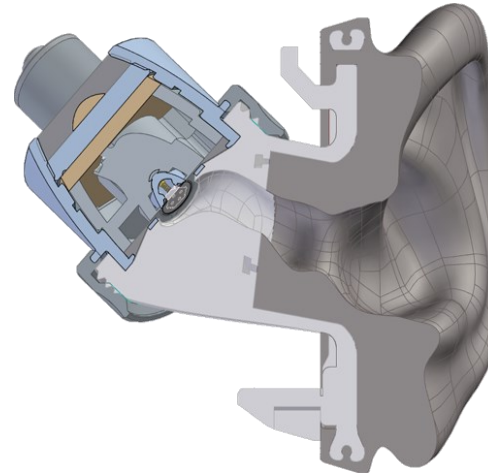
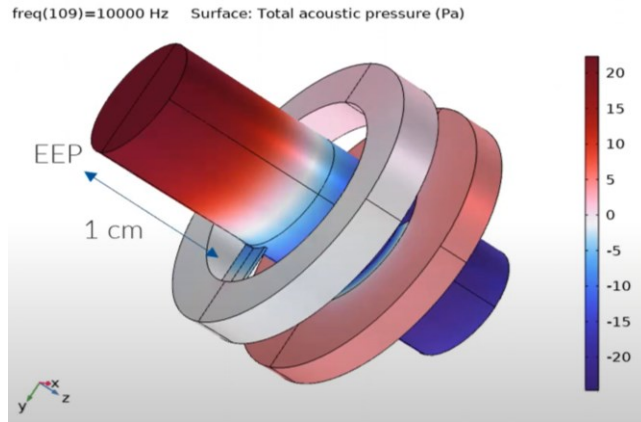

Type 3 711 Coupler vs. Type 4.3 Ear Simulator

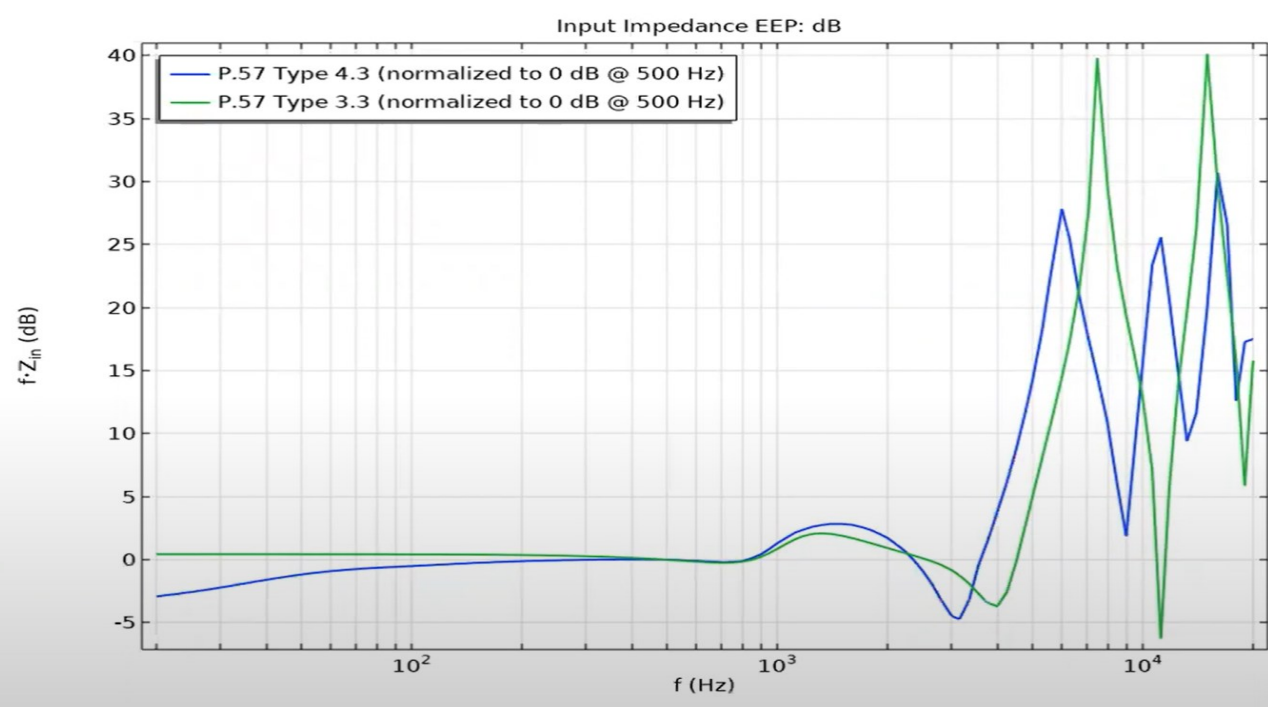
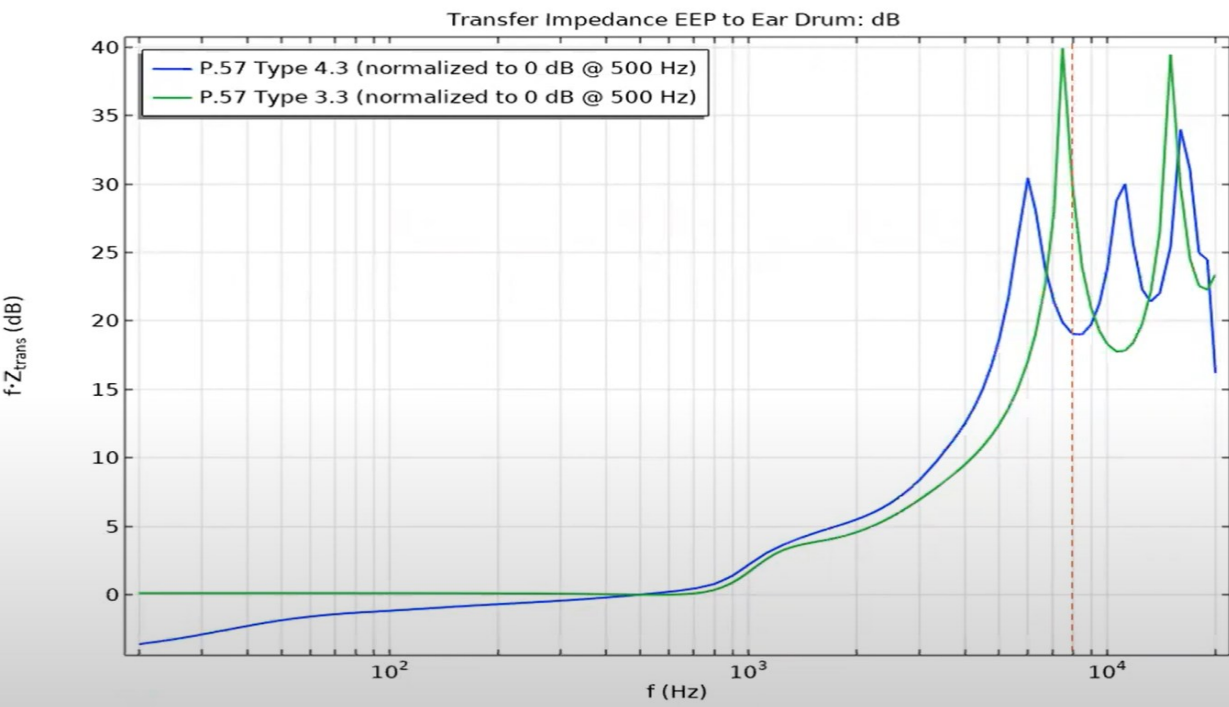
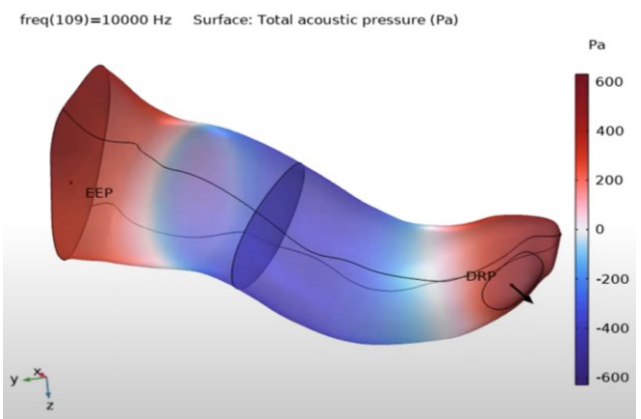
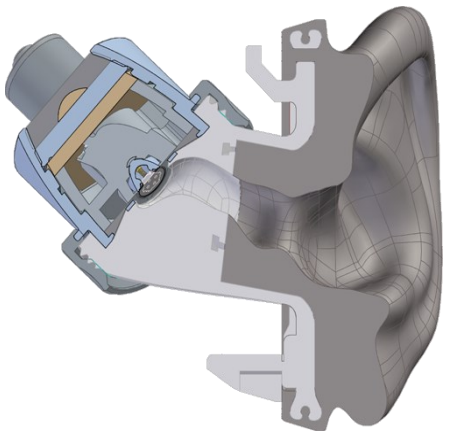
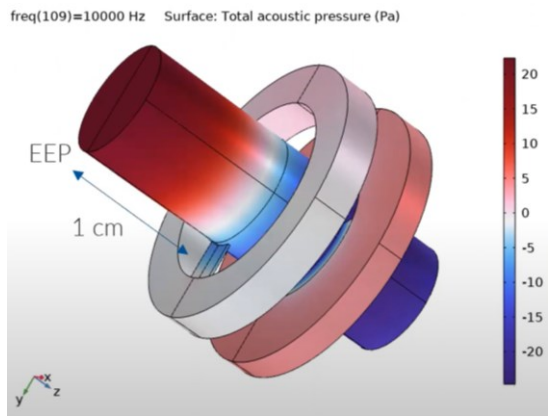

Skyline μ Valve Acoustic Vent – Occlusion Reduction

Skyline μ Valve acoustic vents were developed to remove occlusion effect in TWS earphones, hearing aids, hearing protection devices, and IEMs. A companion control IC is used to change between closed (max isolation), open (vented) and comfort (semi-open) states. Two models available, XSV-1000 (min gap) and XSV-1001 (max gap) providing two different comfort options.

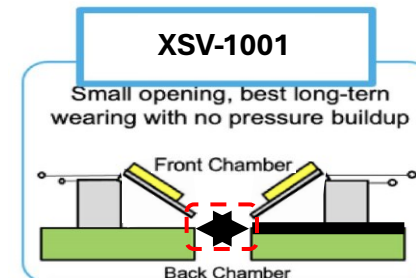
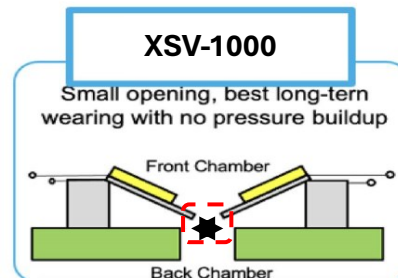
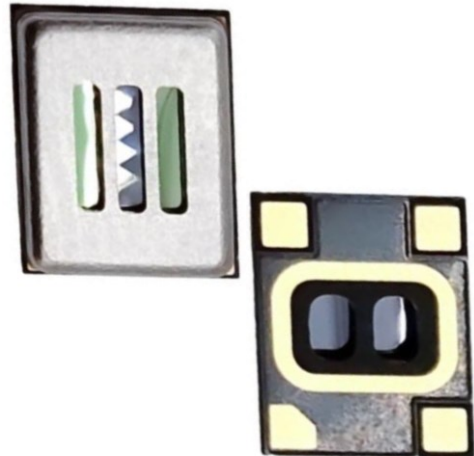
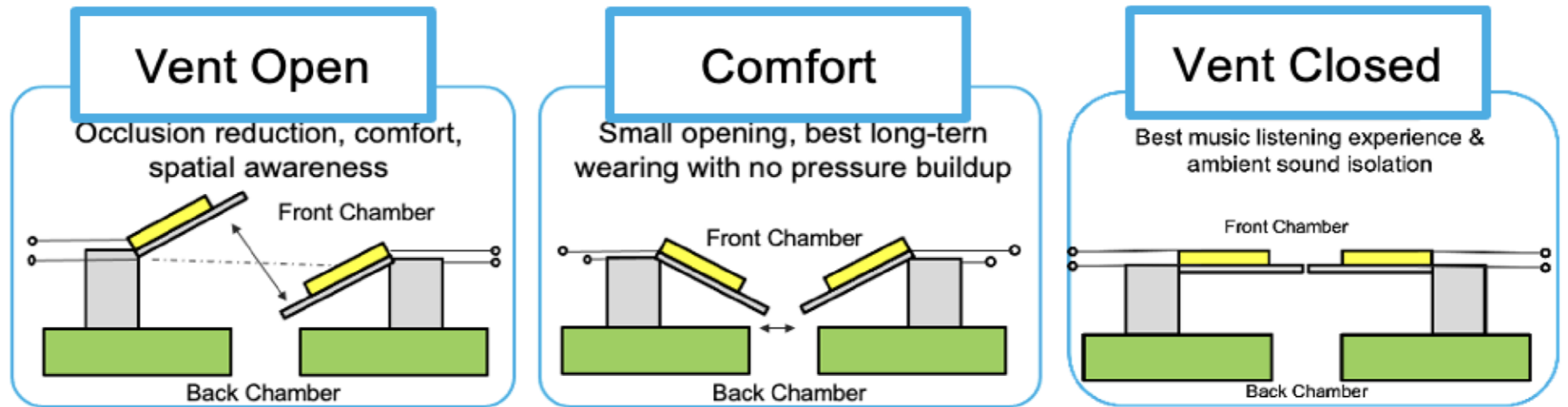

Define Basic Model – Tube Geometries From CAD

Skyline μ Valve

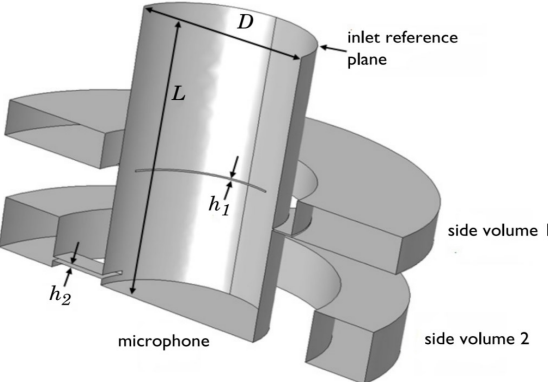
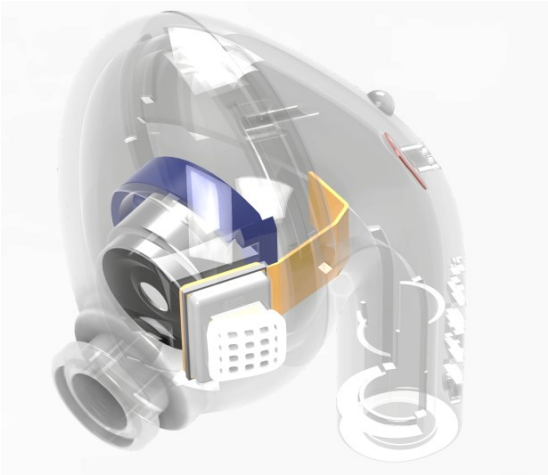
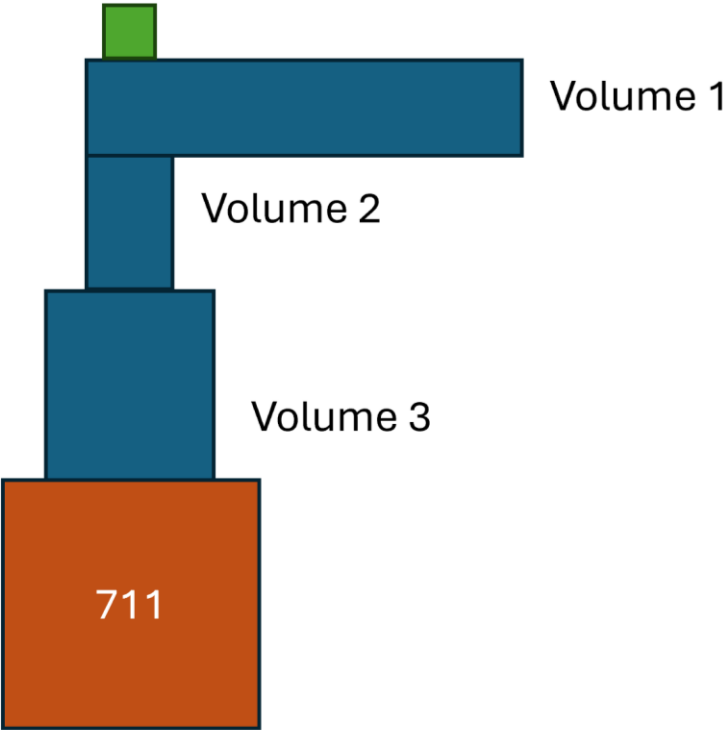

Skyline μ Valve

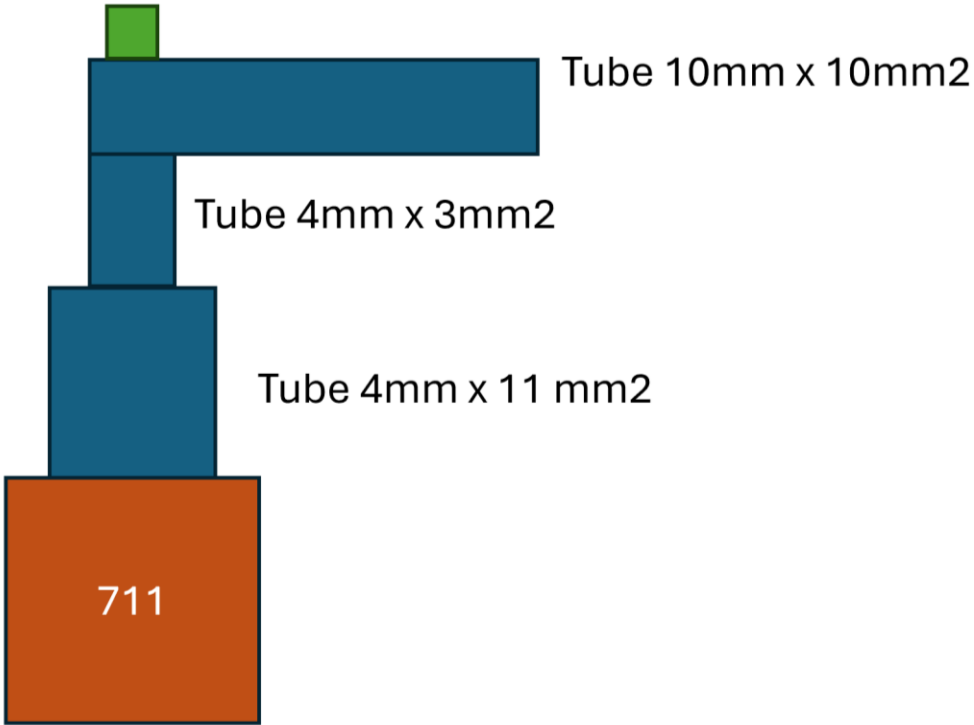

Enable Skyline Mode Switching in COMSOL FEM Model

■ Modify model configuration :

- Current model has provided the impedance information of Skyline's Open/Comfort/Close in "Pressure Acoustic module (PA, acpr)".
- Select frequency domain study as an example. Add study w/ "Frequency Domain" for frequency sweep of SPL level.
- Select "Step 1: Frequency Domain" under Study 1 in Model Builder list before computation.
- Check "Modify model configuration for study step" box in setting window. One can flexibly enable / disable the impedance information for different Skyline modes under PA module.

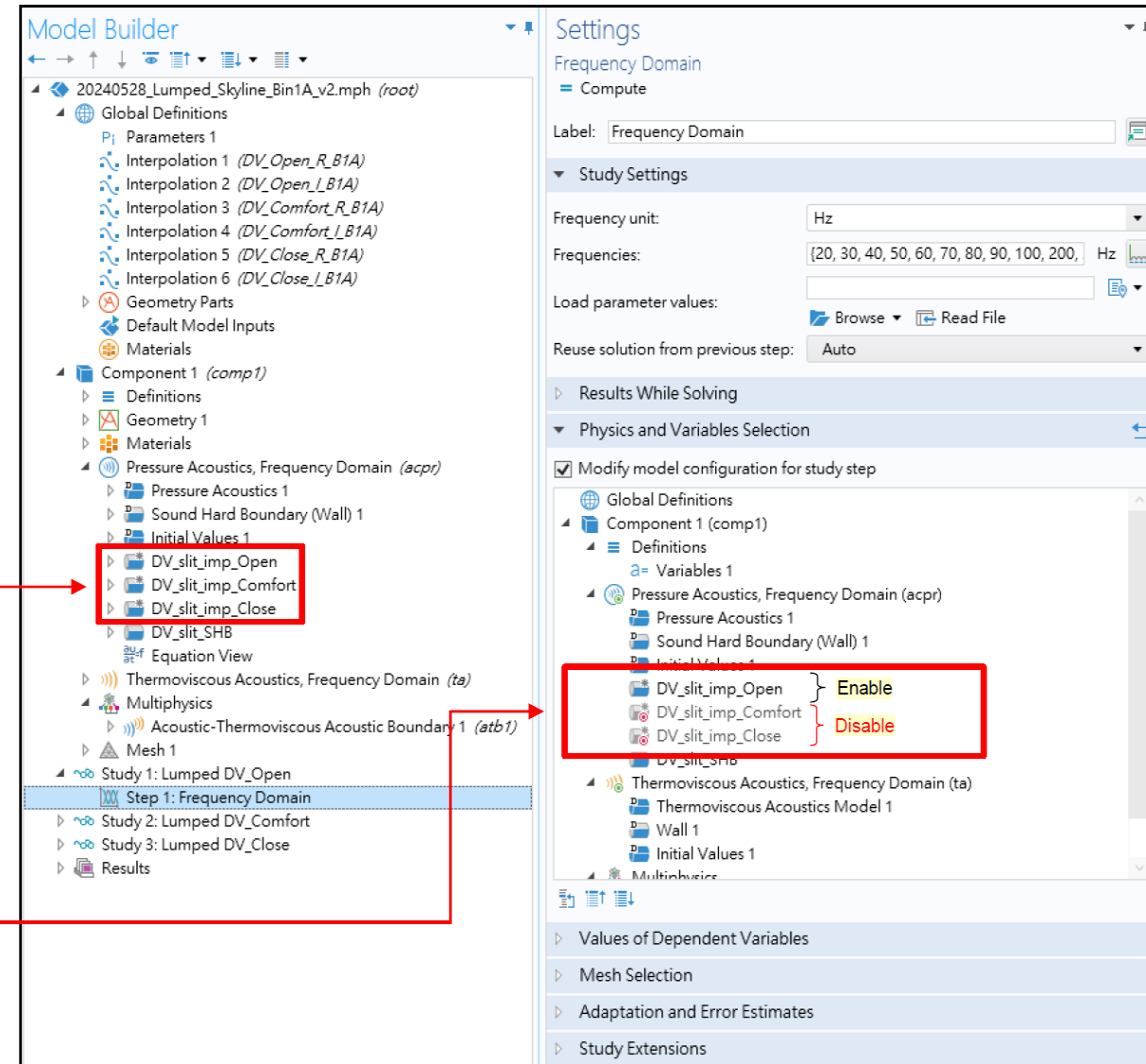

FEM Model Description – Open, Closed And Comfort Modes

Purpose: Establish air-domain model of Skyline component for FEM simulation.

Ventilation behavior is depicted by the user-selected Skyline Mode Switching (Resistance / Reactance tables) for 3 Skyline's operation mode.

Global Definitions

- Parameters 1
- Interpolation 1 (*DV_Open_R_B1A*)
- Interpolation 2 (*DV_Open_I_B1A*)
- Interpolation 3 (*DV_Comfort_R_B1A*)
- Interpolation 4 (*DV_Comfort_I_B1A*)
- Interpolation 5 (*DV_Close_R_B1A*)
- Interpolation 6 (*DV_Close_I_B1A*)

Pressure Acoustics, Frequency Domain (*acpr*)

- Pressure Acoustics 1
- Sound Hard Boundary (Wall) 1
- Initial Values 1
- DV_slit_imp_Open
- DV_slit_imp_Comfort
- DV_slit_imp_Close
- DV_slit_SHB

Possible to switch operation mode

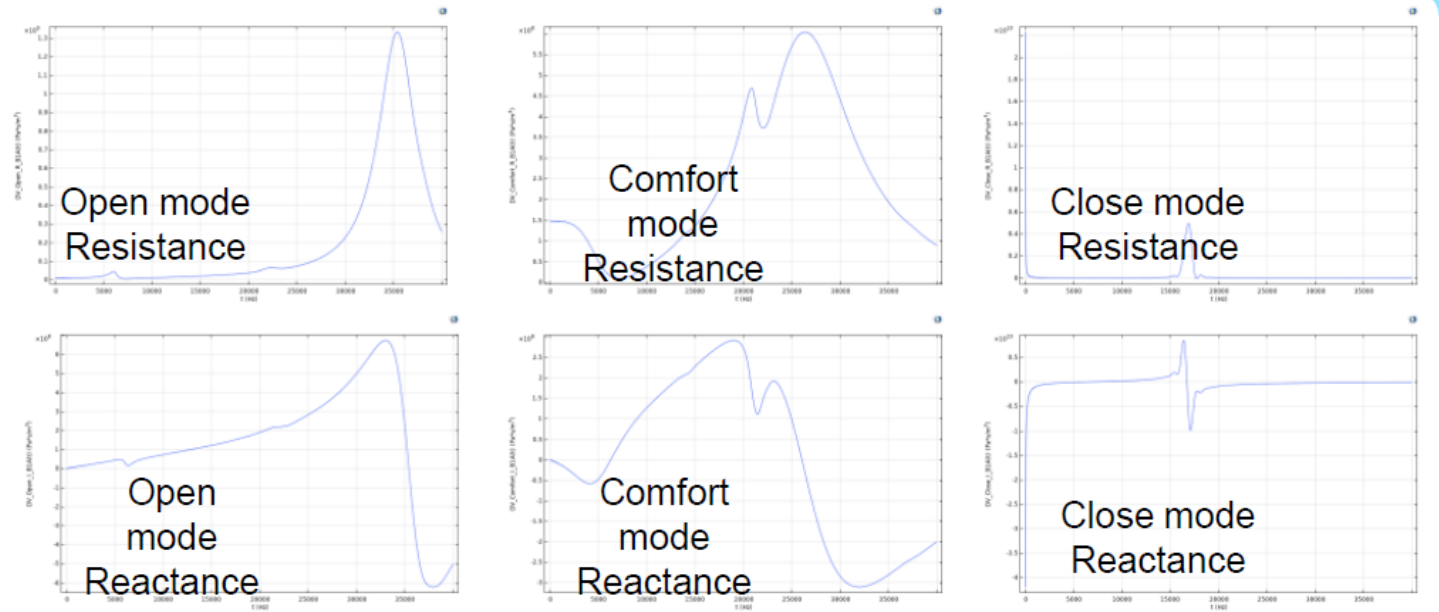

FEM Model Description

A complex solid MEMS is simplified using a lumped interface for faster computation.

- FEM model is a one-way coupling between mechanical and acoustic domain
- Proper simplification of MEMS is useful to achieve the faster computation for a complex MEMS systems.



Solid MEMS + Complex geometry (Air-domain)

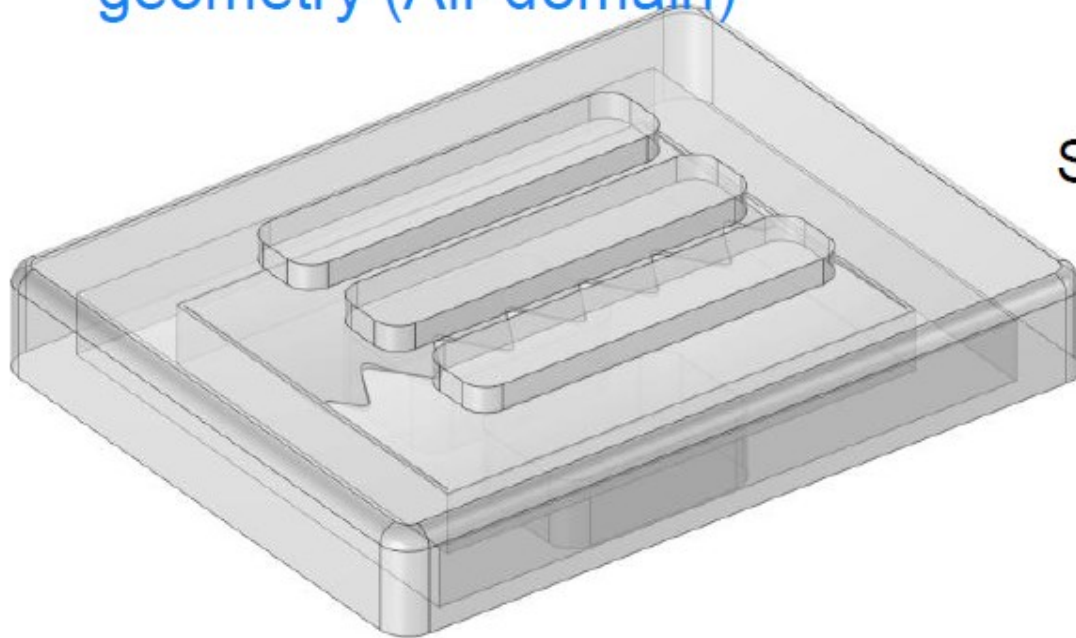

Simplified



Lumped interface + Simplified structure (Air-domain)

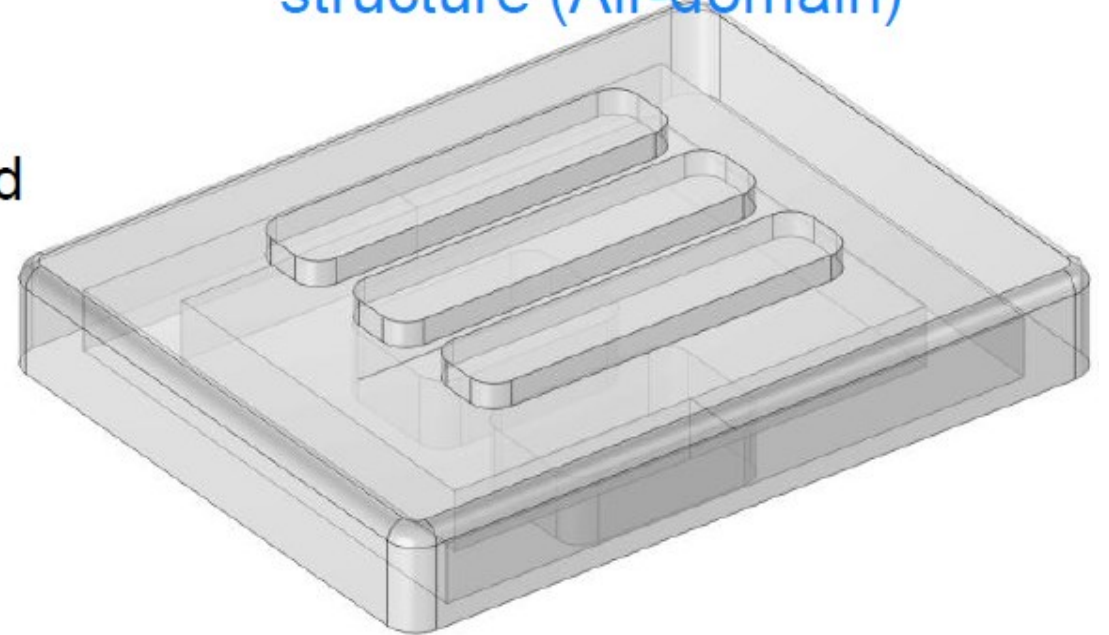

Skyline FPC – Device Level Testing for PoC

- Example Skyline FPC
- FPC now has new lid/substrate per Rev 1.2 datasheet

- FPC Gerber Provided By Email

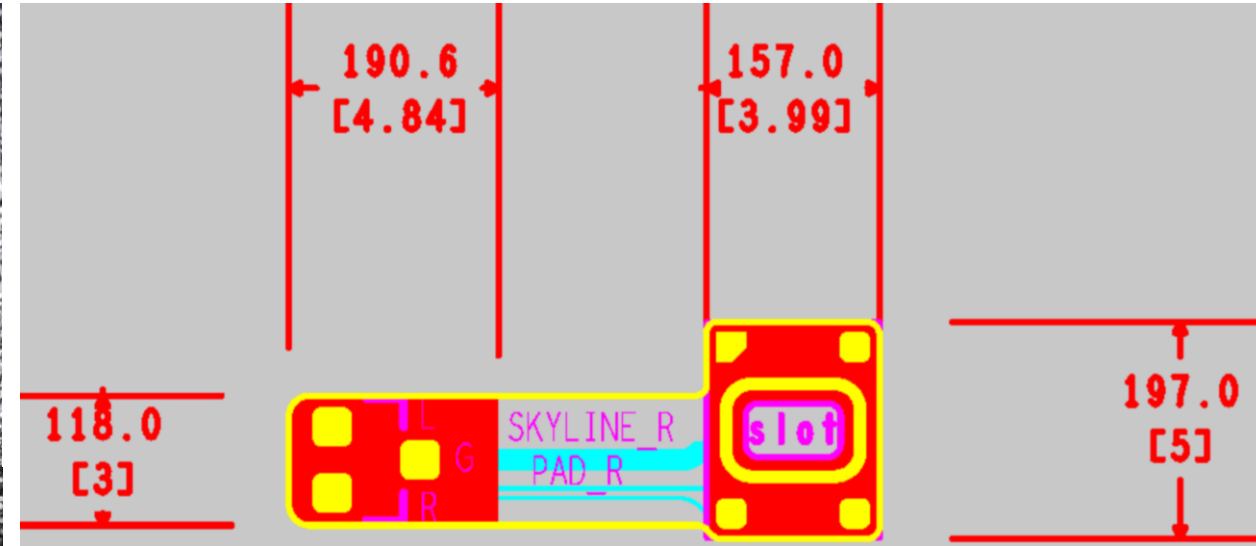

STACKUP

1	POLYIMIDE_FILM_1MIL	1.000	MILS
	ADHESIVE_EPOXY-	1.000	MILS
	COPPER	1.200	MILS
	POLYIMIDE_FILM_1MIL	1.000	MILS
	ADHESIVE_EPOXY-	1.000	MILS
	FR-4	4.000	MILS

FLEX: 9.200 MILS

Skyline Bayonet EVK – Simulated FR Open/Closed Leak Control

XVS-1000 Effects On Frequency Response DD Speaker As Input Stimulus

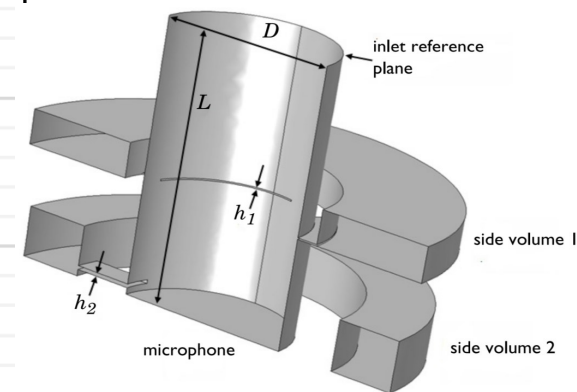
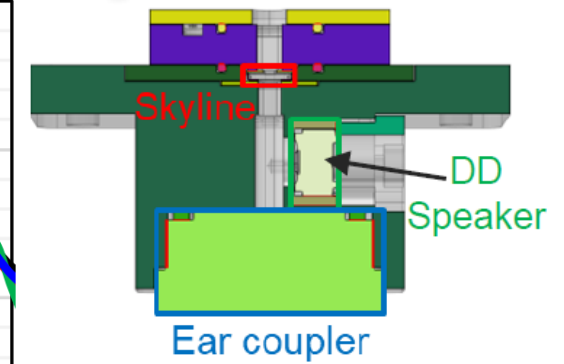
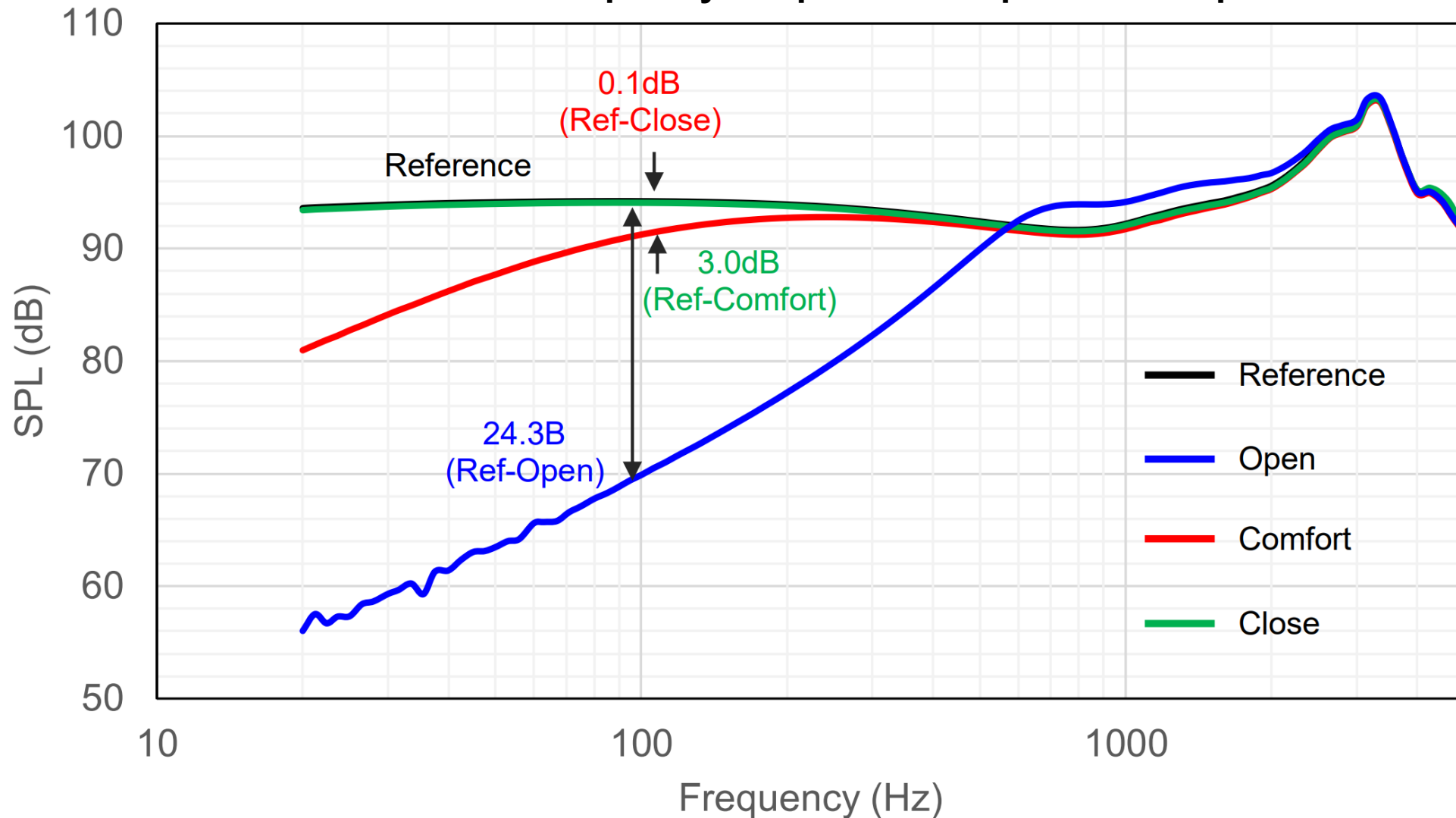

Skyline Bayonet EVK – Simulated FR Open/Closed Leak Control

XVS-1001 Effects On Frequency Response DD Speaker As Input Stimulus

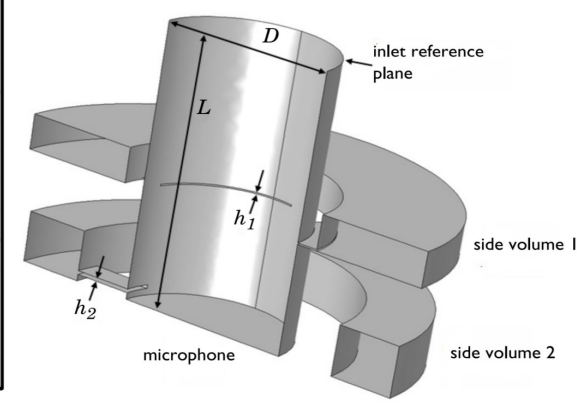
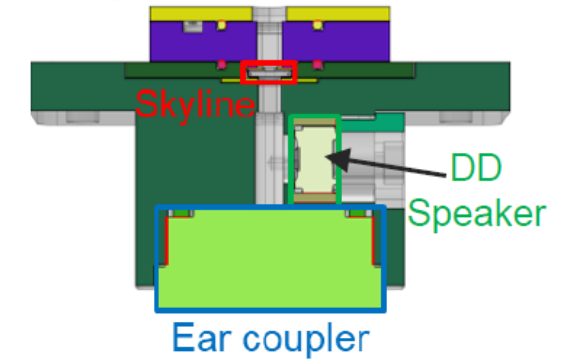
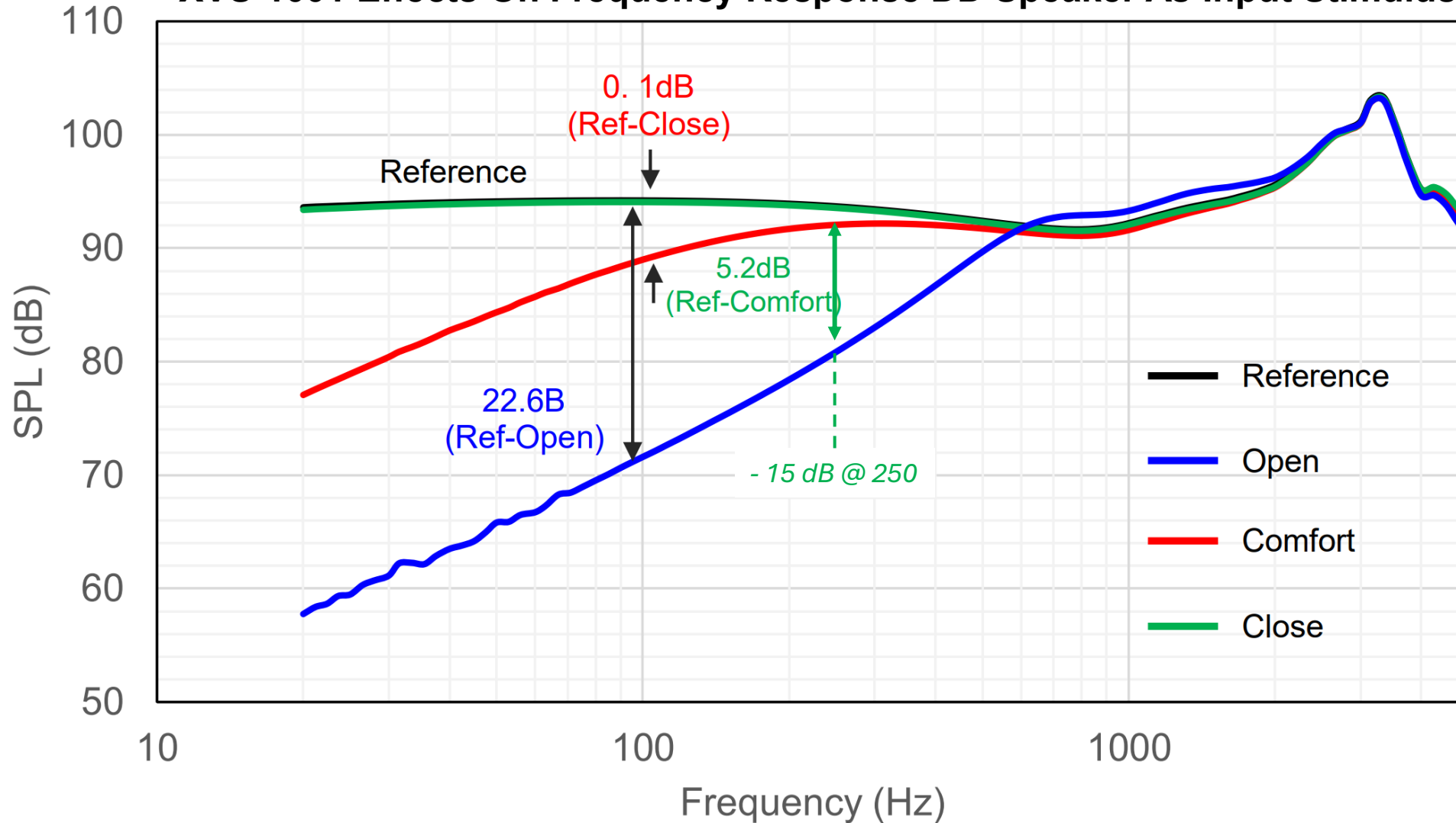

Validate Skyline Bin1B FEM Model

- Purpose: Validate Skyline Bin1A FEM model: 20240719_Lumped_Skyline_Bin1A_v3.mph
- Measurement Setup: MP Skyline with wide-opened lid in bench tester.
- Simulated Skyline Bin1A FEM results match the measured response well
 - Lumped-based Skyline performs **LFRO_{100Hz} = 21.9dB**, very close to measured LFRO(22.6dB).

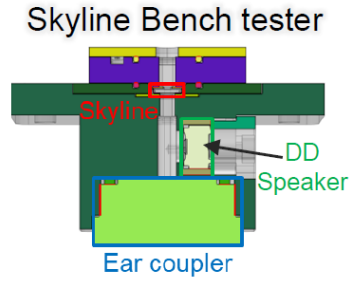

Measured Frequency Response DD Speaker

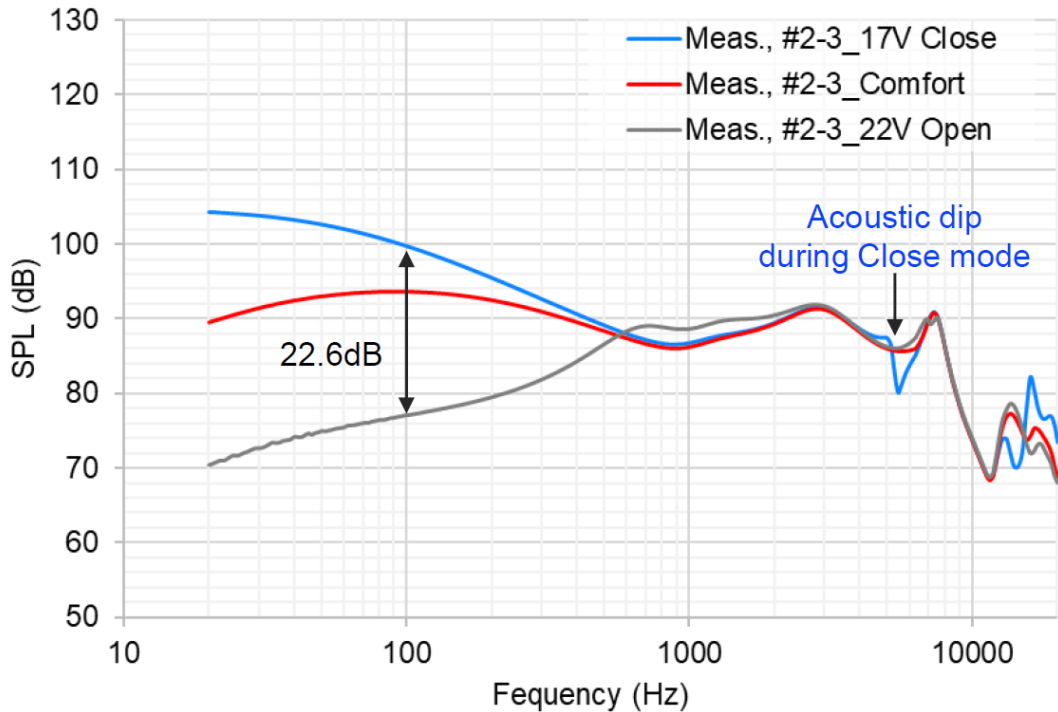

FEM Simulated Frequency Response DD Speaker

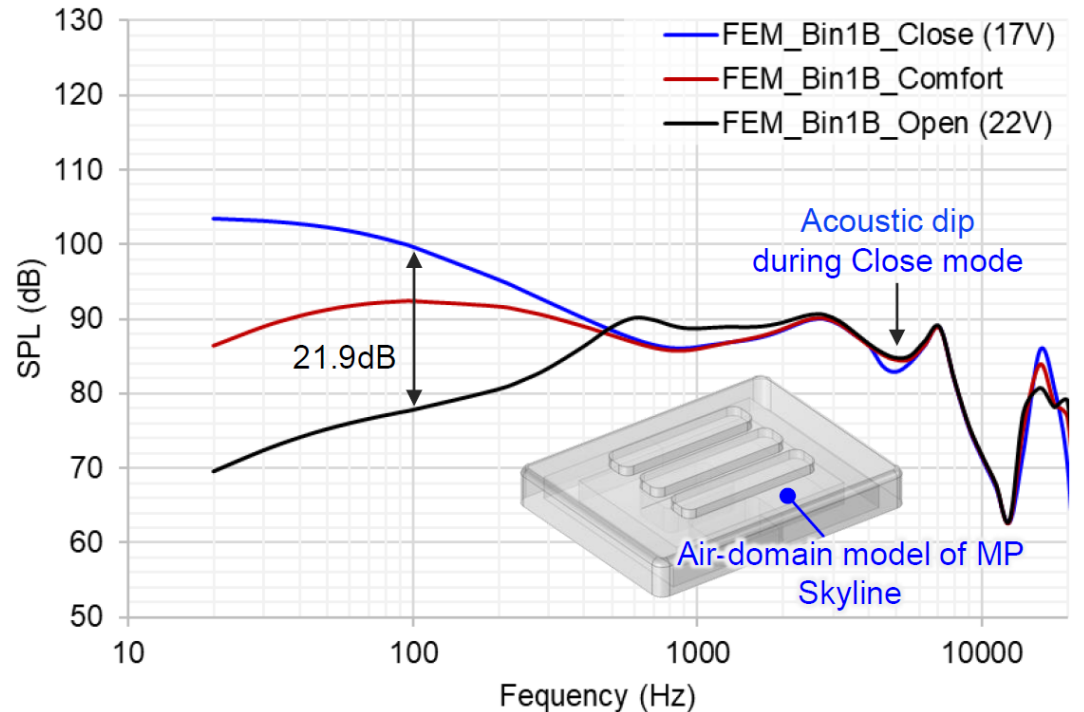

Validate Skyline Bin1A FEM Model

- Purpose: Validate Skyline Bin1A FEM model: 20240719_Lumped_Skyline_Bin1A_v3.mph
- Measurement Set Up - Skyline with wide-opened lid in bench tester.
- Simulated Skyline Bin1A FEM results match the measured response well
 - Lumped-based Skyline performs $LFRO_{100\text{Hz}} = 23.3\text{dB}$ between Open/Close model, very close to measured LFRO (23.9dB).

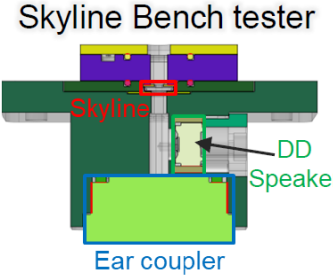

Measured Frequency Response DD Speaker

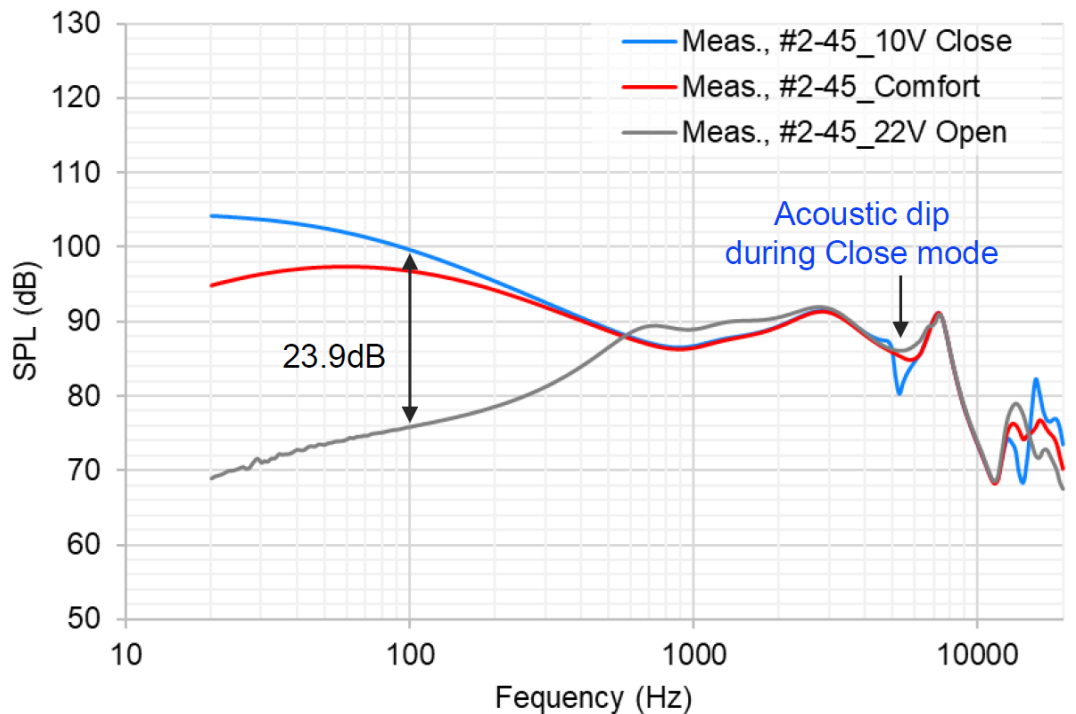

FEM Simulated Frequency Response DD Speaker

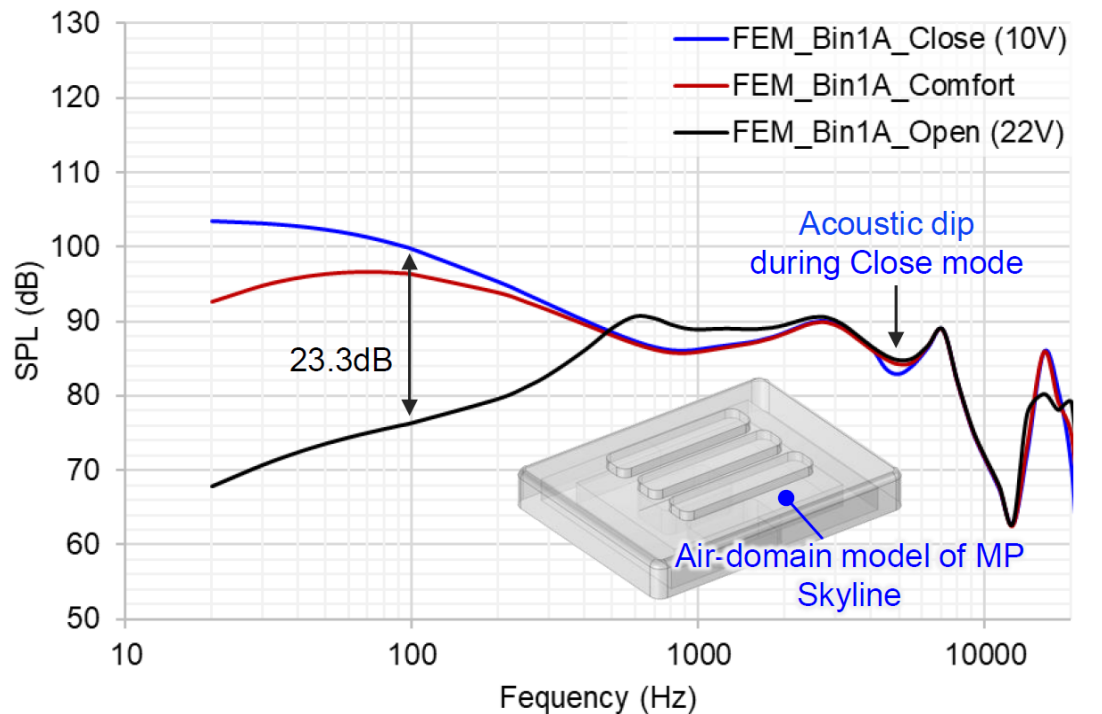

Skyline μ Valve Device Level – Acoustic Vent Test Set Up

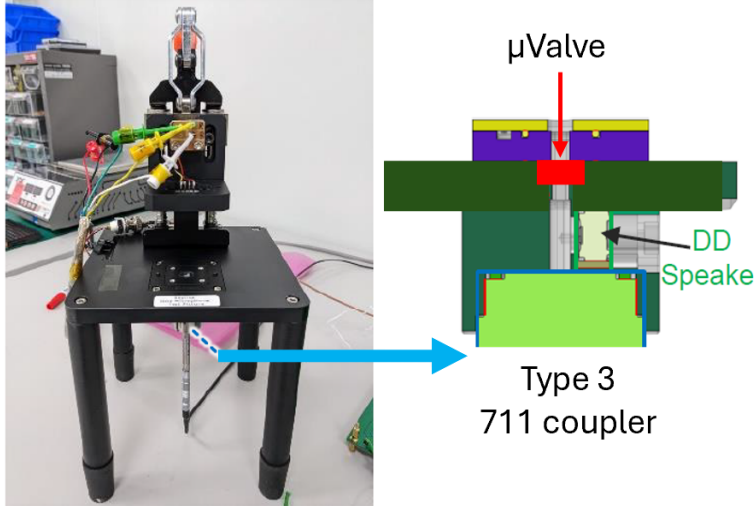
Test Fixture	Bench socket "One Microphone Test Fixture"
<p>Plots of Bench Tester :</p> <p>DUT front-side condition: 1.5cc</p> <p>DUT back-side condition: Vent to Air</p>	

Test Signal chain:

Bench Tester

DAC of Measurement System → DD speaker → Skyline → Microphone →
Microphone Power Module → ADC of Measurement System

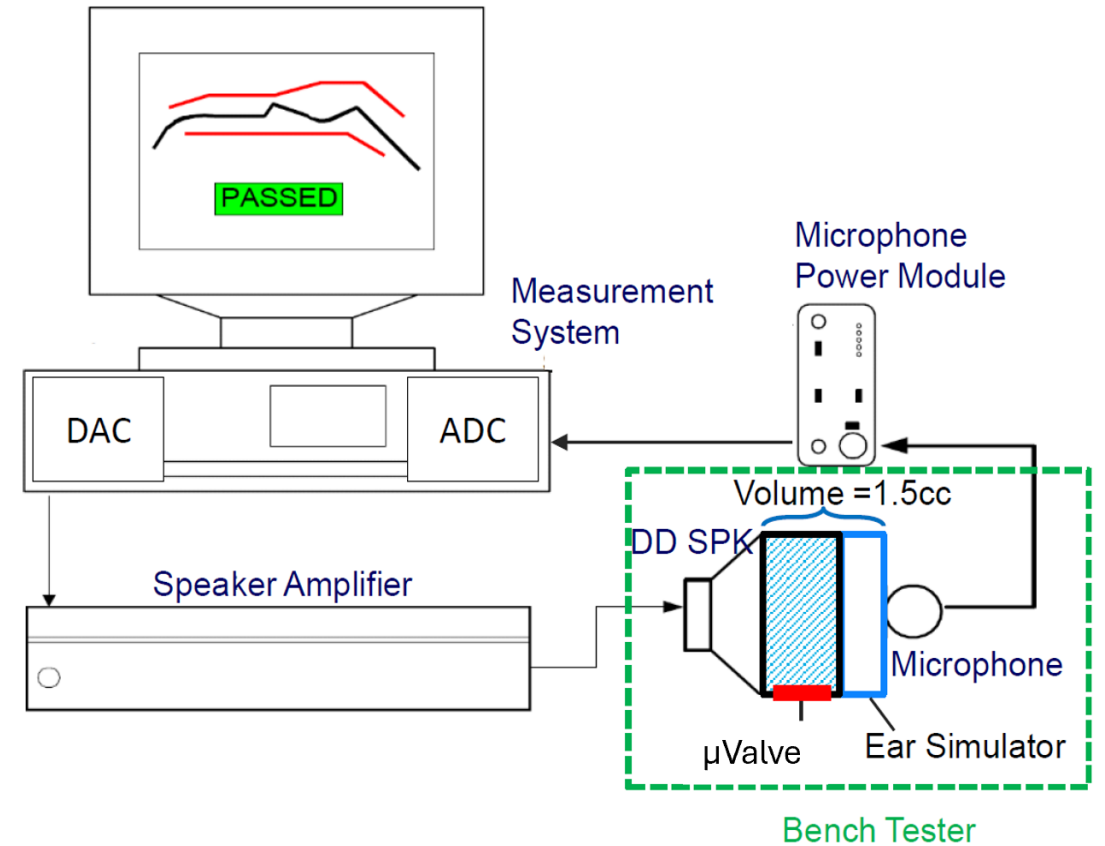

Passive Attenuation

The simulations are based on passive attenuation measurement for ANC/PNC products.

Test setup

- Reverberation chamber and pink noise.
- 1- Measure coupler/HATS
- 2- Measure DUT on coupler/HATS
- 3- Calculate delta

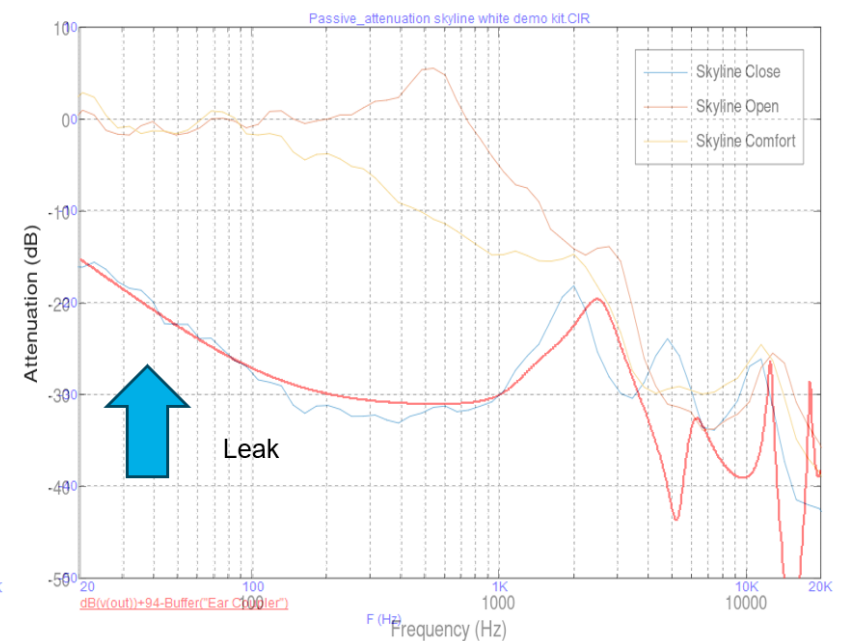
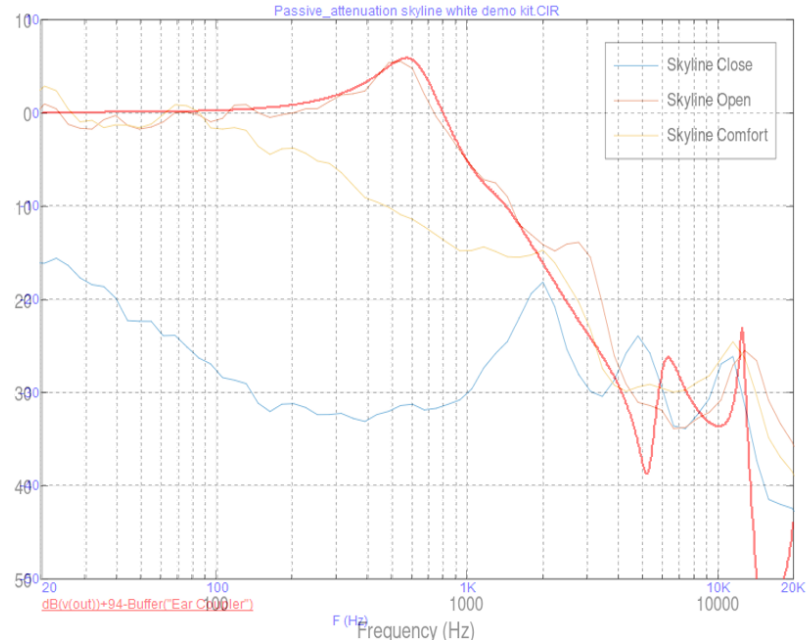
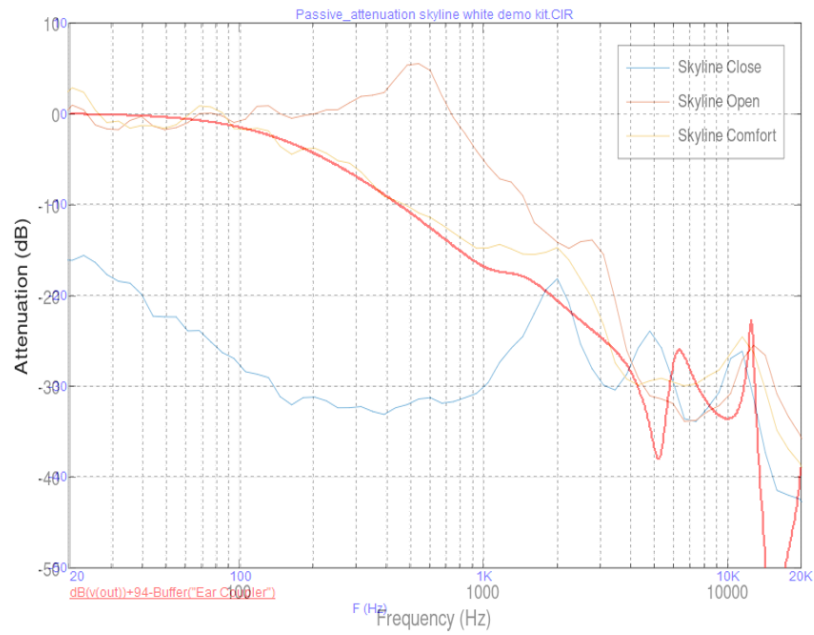
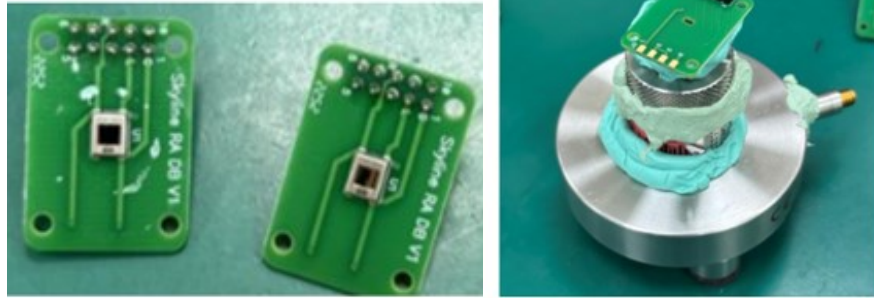

Device - Internal Seal Test

Audio test of prototype internal acoustic seal
3D Printed housings w/Skyline installed
Verify no leaks in housing to verify expected LFRO
DC bench supply to activate Skyline
B&K acoustic isolation box w/6" dynamic driver

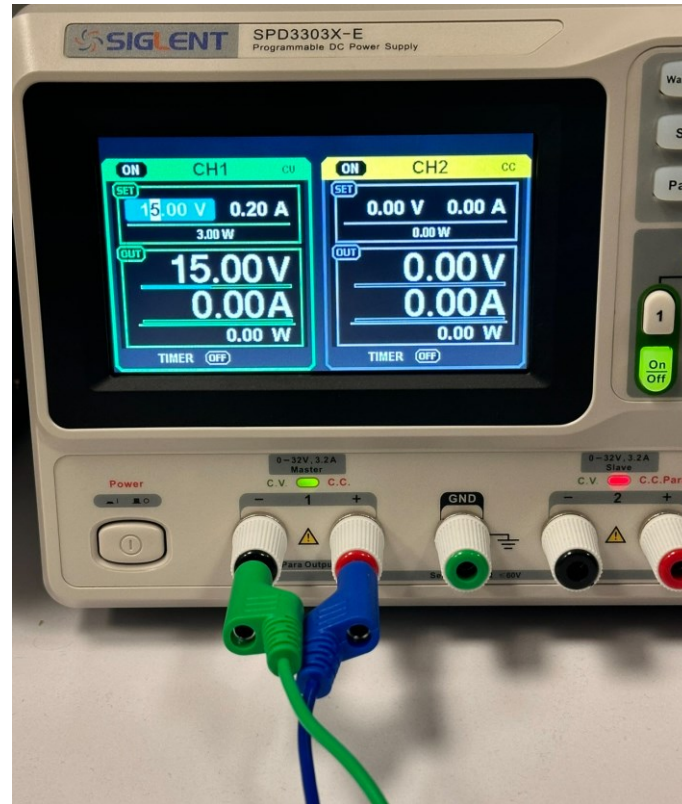
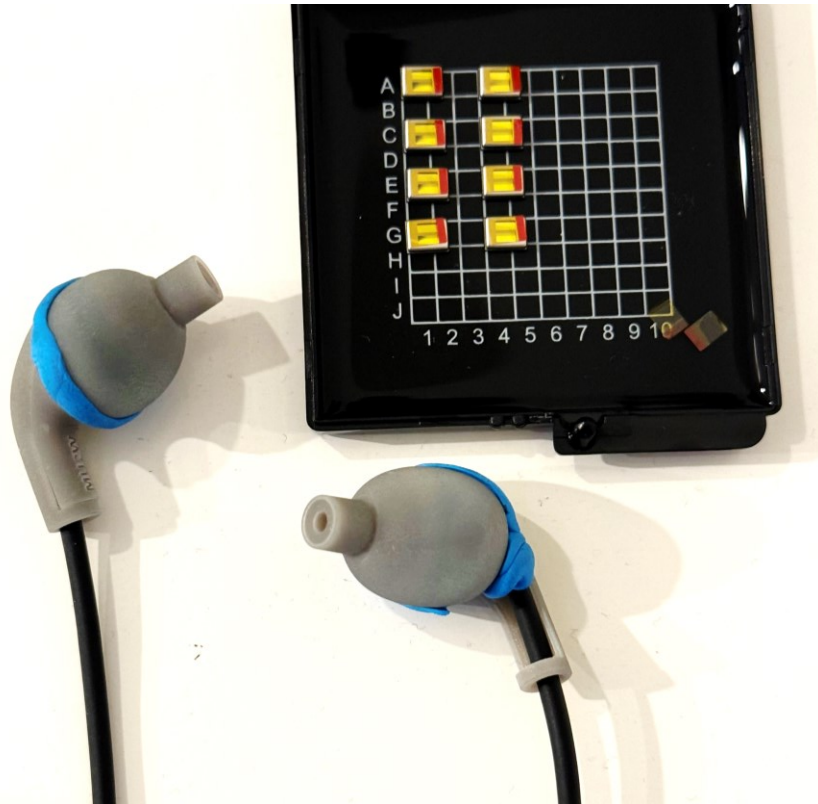

Device - Internal Seal Test

3D printed housing assembled correctly
Skyline exhibits expected LFRO in prototype

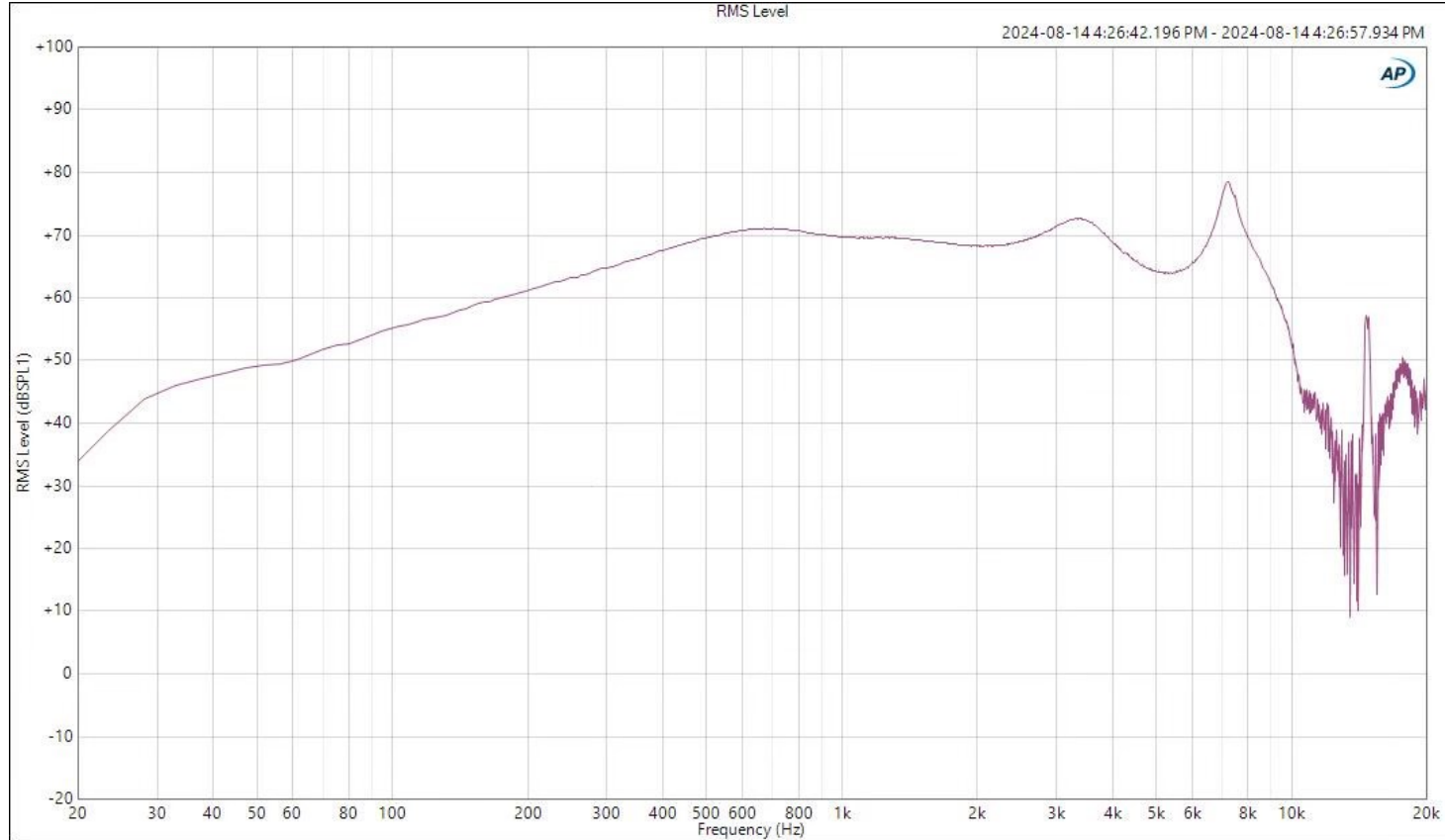

Skyline Housing - Occlusion Reduction EVK

Simulate occlusion reduction using housing's internal geometries and leak ports with Skyline lumped model

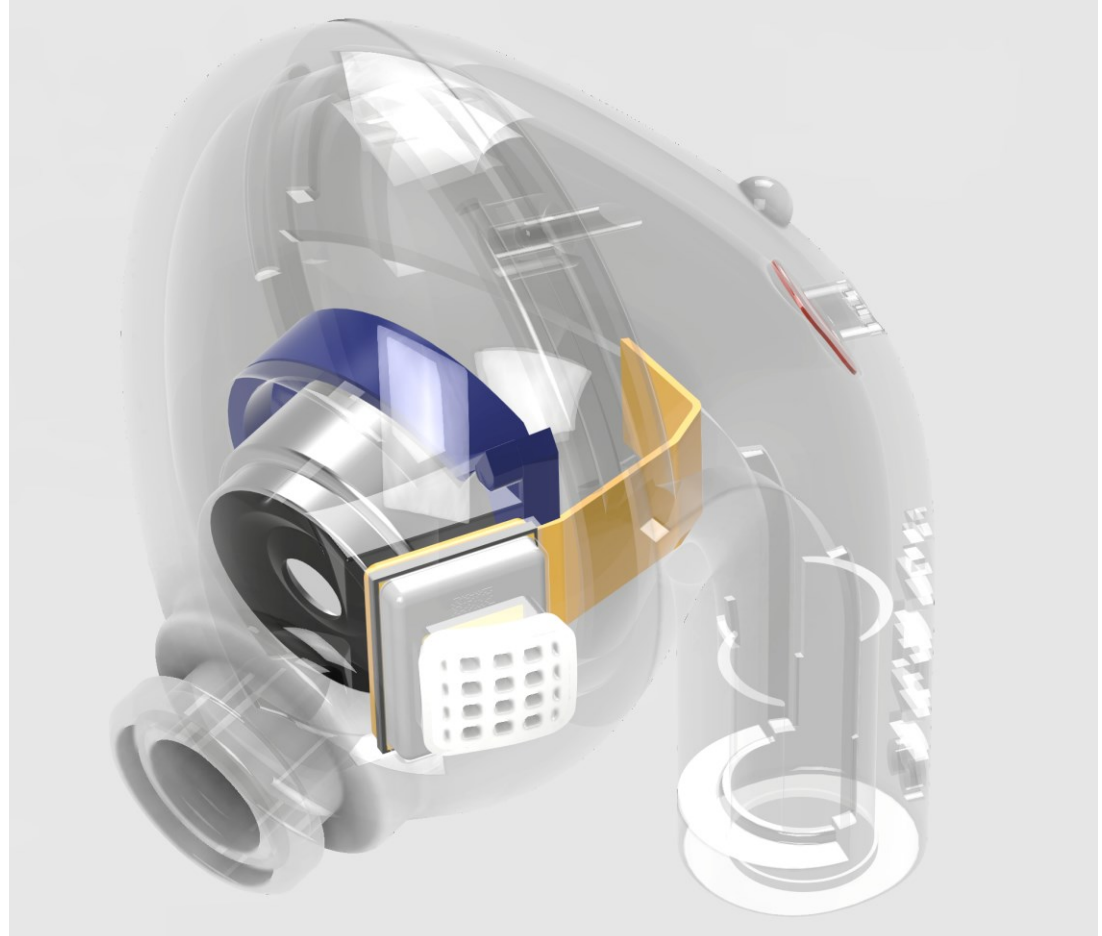
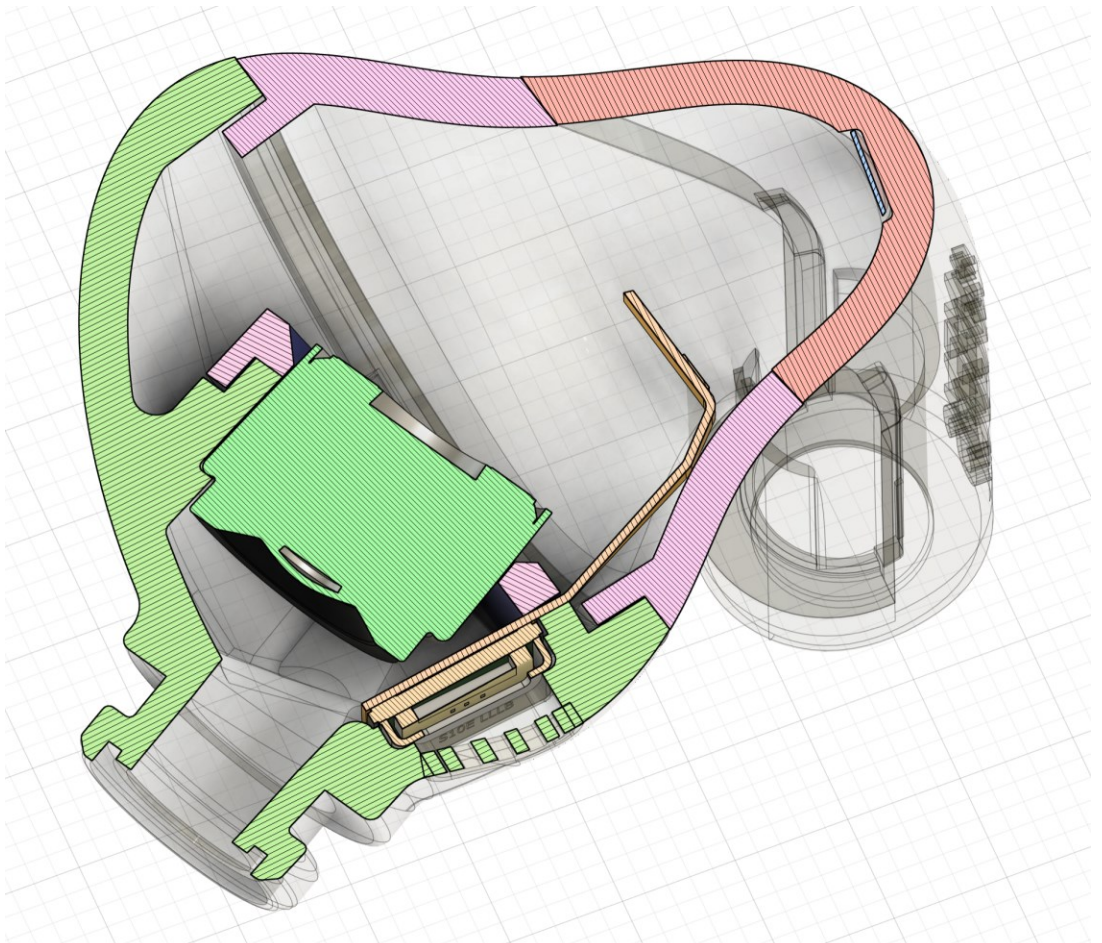

Skyline EVK Frequency Response Measurement - Open/Closed



Report Header:	B&K 4987 - 711 Coupler
Test Engineer:	Pierce H
Time:	5/20/2024 11:26
DUT:	Skyline + DD Bayonet EVK
Input Stimulus:	100mV
Serial #:	

Correlates with simulation!

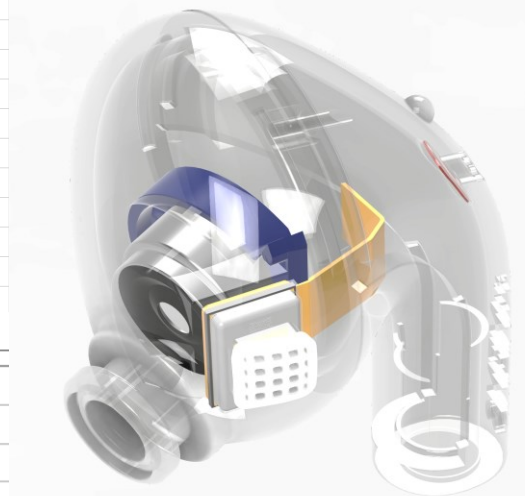

Amplitude response

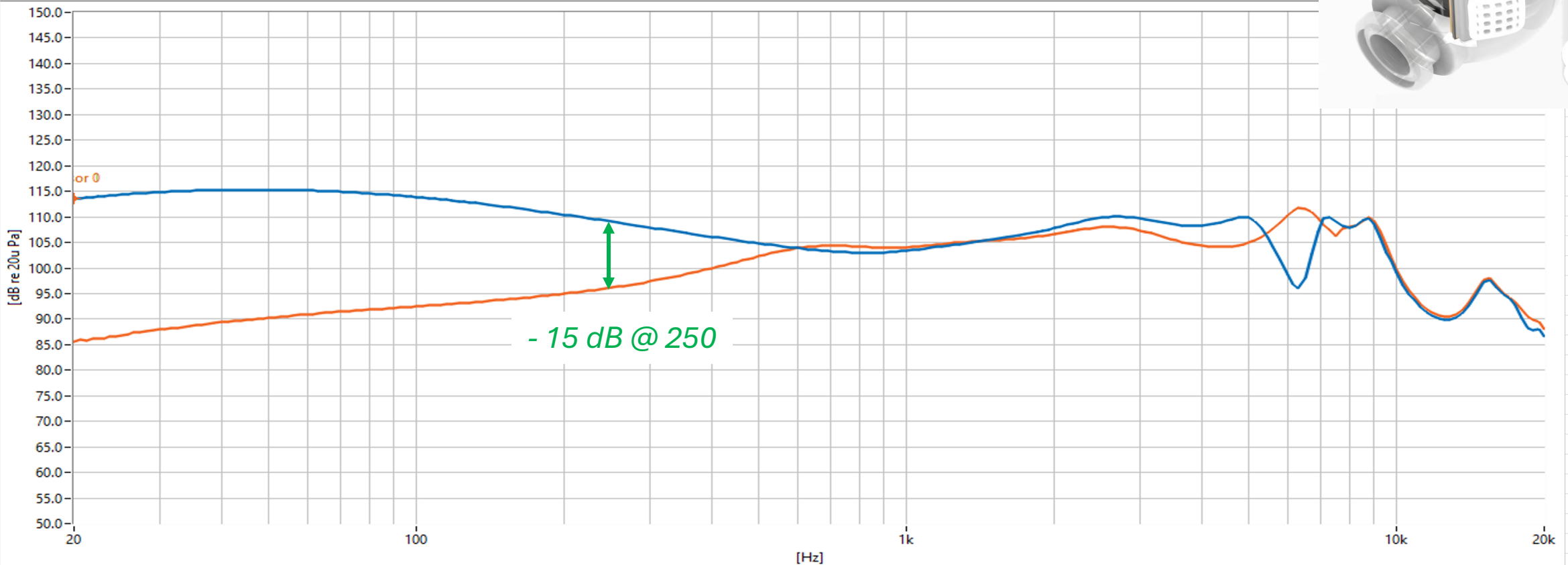

Skyline Datasheet Rev 1.2

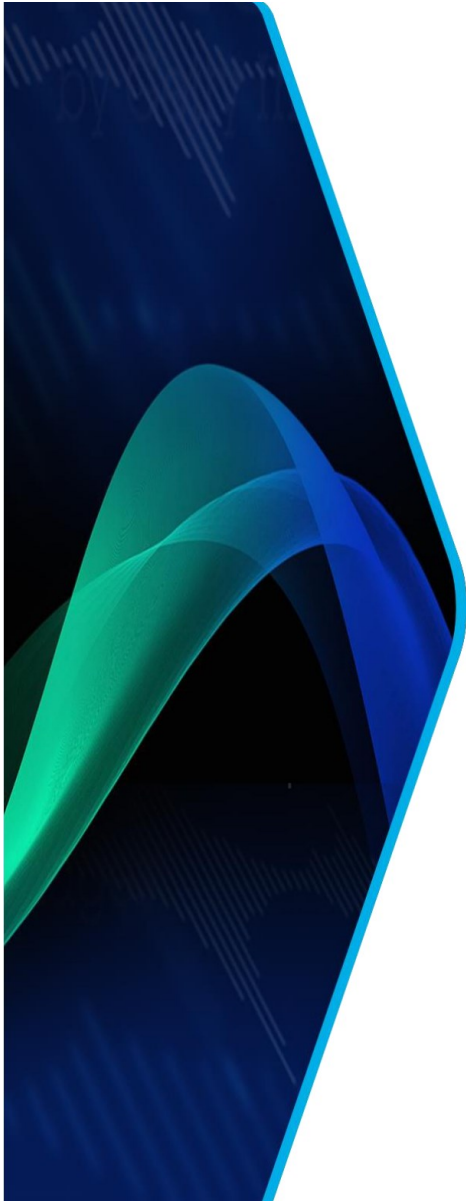

True MEMS Speakers
Santa Clara, CA
www.xmems.com
support@xmems.com

DATASHEET

XVS-1000 / XVS-1001
Skyline Dynamic Vent

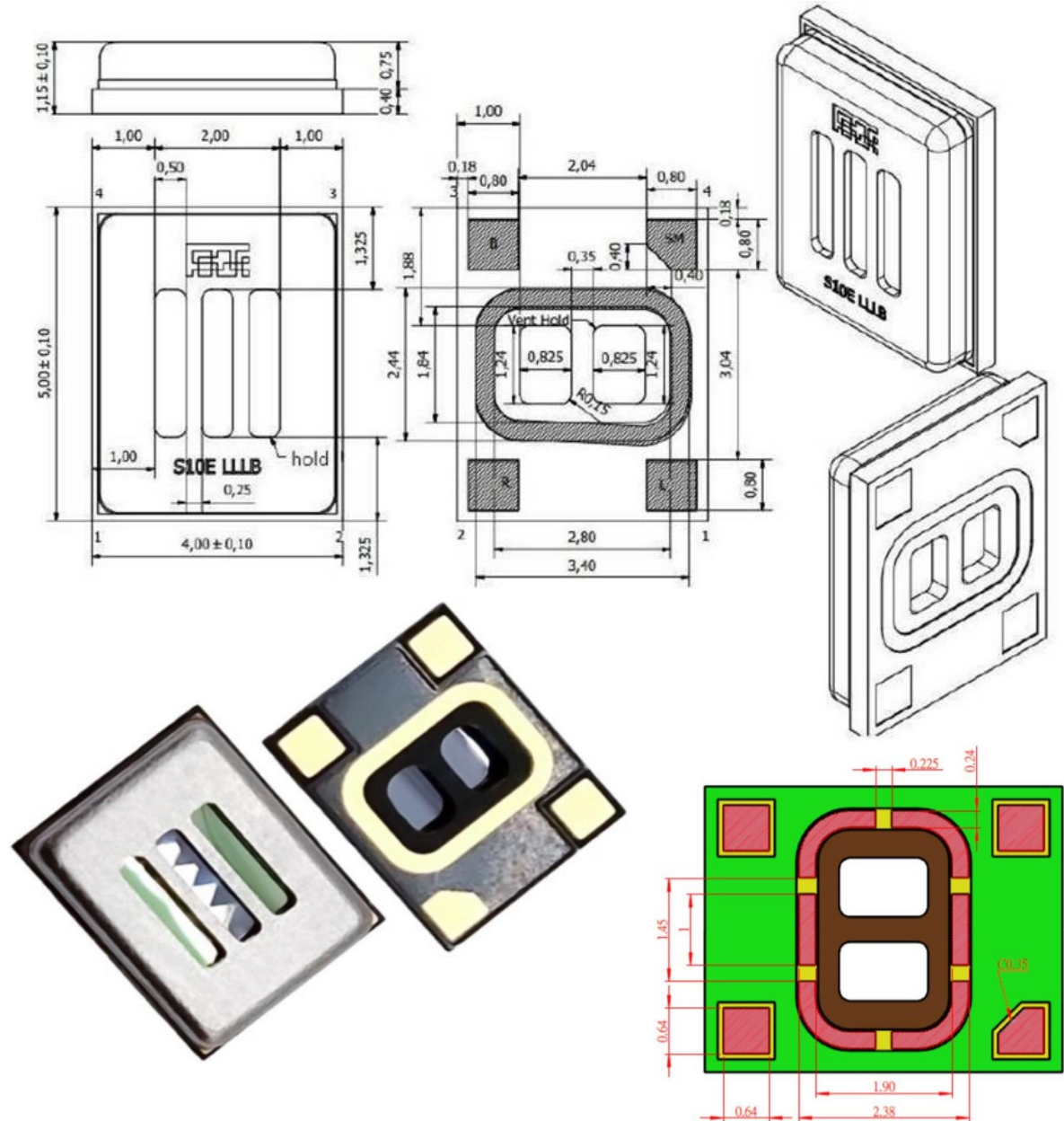

xMEMS 7-25 Update – Alpine Datasheet Rev 1.2 Sent



True MEMS Speakers
Santa Clara, CA
www.xmems.com
support@xmems.com

Datasheet

XDA-1000 / XDA-1001

Single-Channel
Alpine Driver
for xMEMS
DynamicVents

Document Revision 1.2
June 2024

- Open mode = 22V
- Close mode = 10V (XDA-1000) 17V (XDA-1001)

Alpine & Skyline: Transition Times

Transition times were optimized for avoiding audible effect, and measured with 0.28cc front volume in tester.

Operation Mode	From State	To State	Typical Transition Time (Sec)
Standard Mode	Comfort	Open	1.5
	Open	Comfort	1.5
	Close	Open (XDA-1000)	1.5
	Close	Open (XDA-1001)	1
	Open	Close (XDA-1000)	1.5
	Open	Close (XDA-1001)	1.5
	Comfort	Close (XDA-1000)	1.5
	Comfort	Close (XDA-1001)	1.5
	Close	Comfort (XDA-1000)	1.5
	Close	Comfort (XDA-1001)	1.5
Gunshot Mode	Open	Close	<0.1
	Comfort	Close	<0.1



A Brief Use Case Study: In-Ear Monitors

Current IEMs Have Functional Limitation

- No occlusion relief
- No side-tone for hearing natural voice
- No ambient passthrough of stage or audience sound
- Forces higher SPL monitoring for vocalists = unsafe monitoring levels
- Requires additional mics set up for stage communications and audience feed



Occlusion Effect For Vocalist + 25 dB (or higher) at 250 Hz

Occlusion effect for vocalist is much more severe due to elevated singing voice. Reducing head-voice allows for a lower monitor mix as instrument levels can now be reduced.

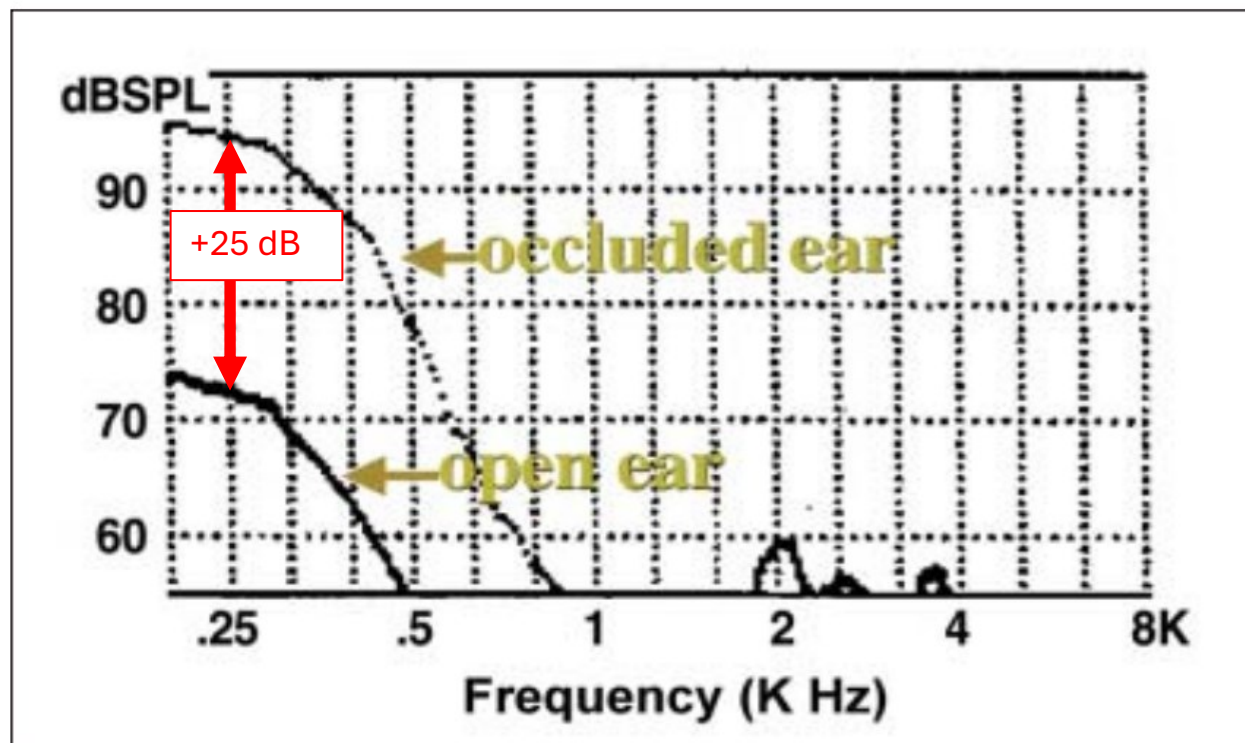
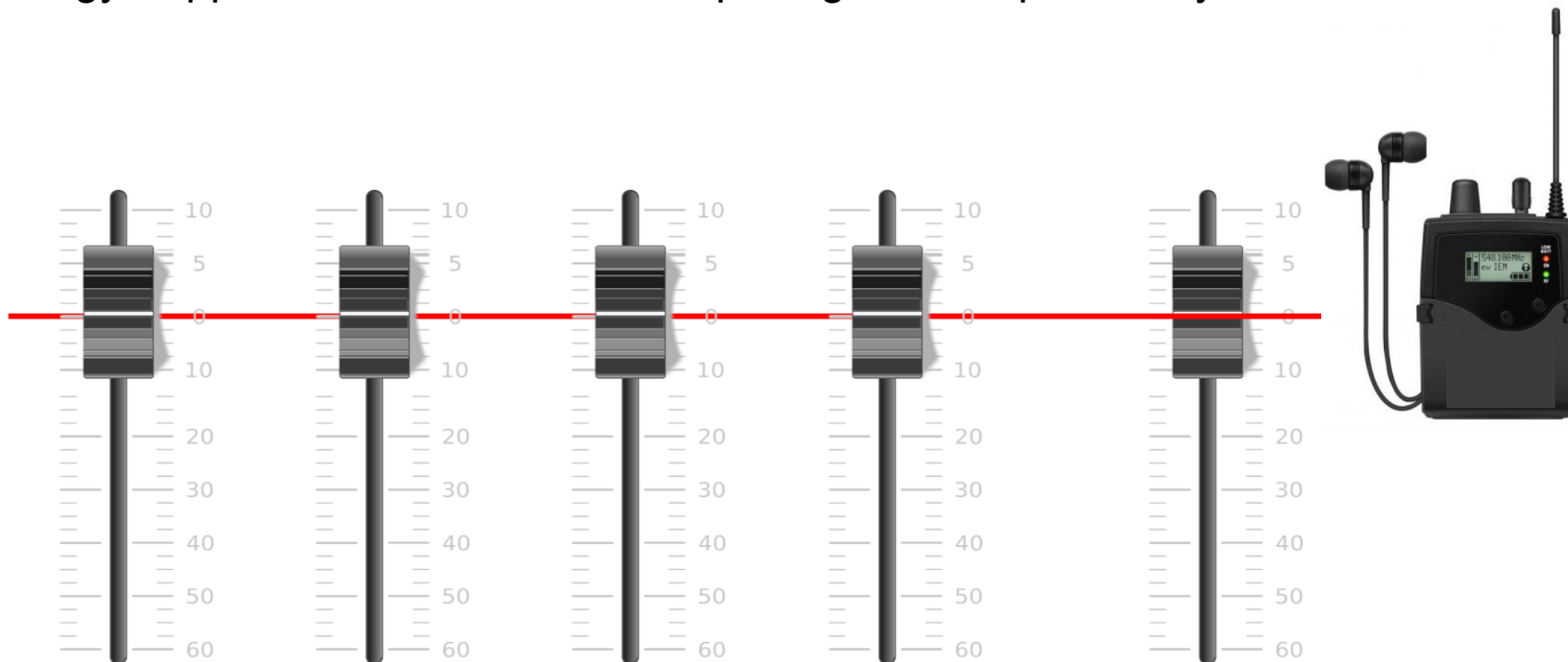

Figure 1. *Real ear response of /i/ measured in an open-ear and an occluded ear condition.*



Typical Monitoring Levels – Occluded IEMs

Vocalist always need higher monitoring levels of band instrumentation to overcome their head-voice sound energy trapped in their ear canals, exposing them to potentially unsafe SPL and transients while performing.



Higher volume sent to singers IEMs to match head-voice



IEM Ambient Passthrough + Occlusion Relief When Open

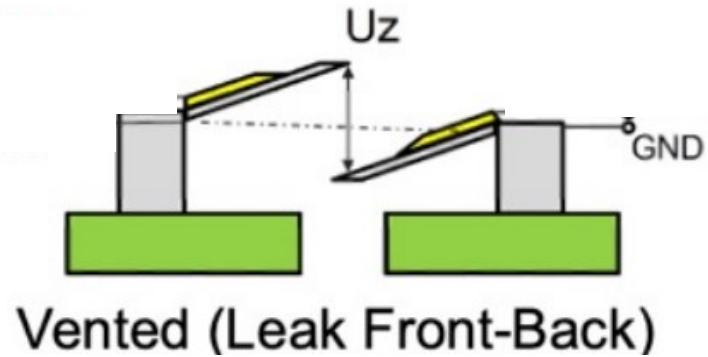

Provides ambient passthrough of stage and audience sound.

Enables verbal communication with bandmembers and production staff without removing IEM from the ear.

Provides side-tone for natural perception of singing voice, helping vocalist stay in tune and control pitch.

Restores exciting sensation of performing live.



IEM Ambient Passthrough of Audience and Stage Sound



Safer Monitoring Levels – IEMs w/Skyline Vents Open

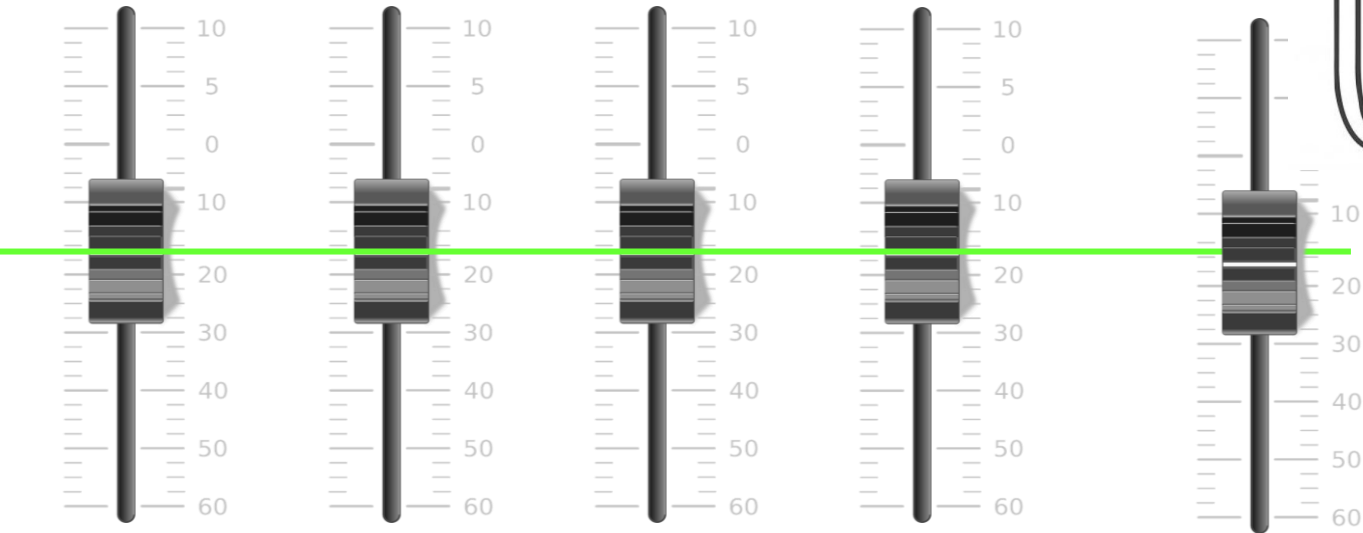
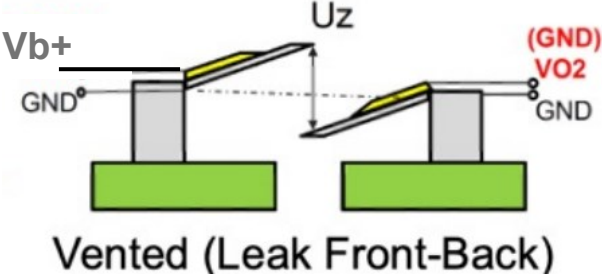

Lower monitoring level from open vent providing occlusion relief

Control Fully Occluded – 35 dB Passive Attenuation

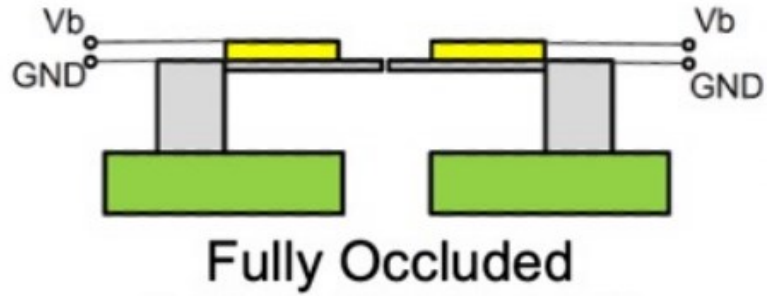

Acoustic isolation when closed in monitoring mode



CONCLUSIONS

Using controllable acoustic vents in an occluded fit TWS earphone can reduce ear canal pressure when opened, providing significant occlusion relief. Users can lower the volume to a comfortable listening level while enjoying a more natural conversation when taking calls with increased side-tone perception. Opening controllable acoustic vents allows external sounds to enter the listening device and passthrough into the ear, enabling users to hear environmental sounds, enhancing awareness. Controllable acoustic vents in an IEM allows musicians to significantly reduce head-voice levels experienced when singing, allowing a lower volume (safer) monitor mix. COMSOL Multiphysics was a critical tool in the development of these Piezo-MEMS acoustic vents. Simulation of target use cases validated with physical testing accelerated product development of safer products with new desirable features.

Open = Occlusion Reduction

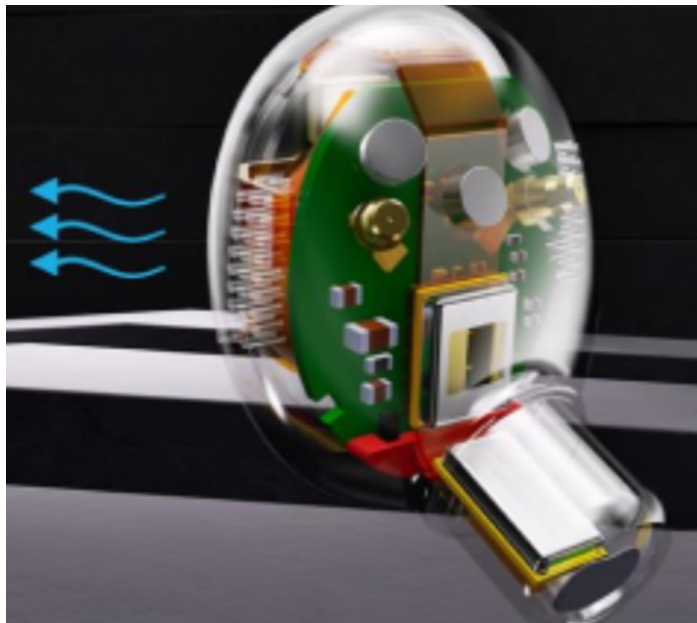

Closed = Passive Attenuation

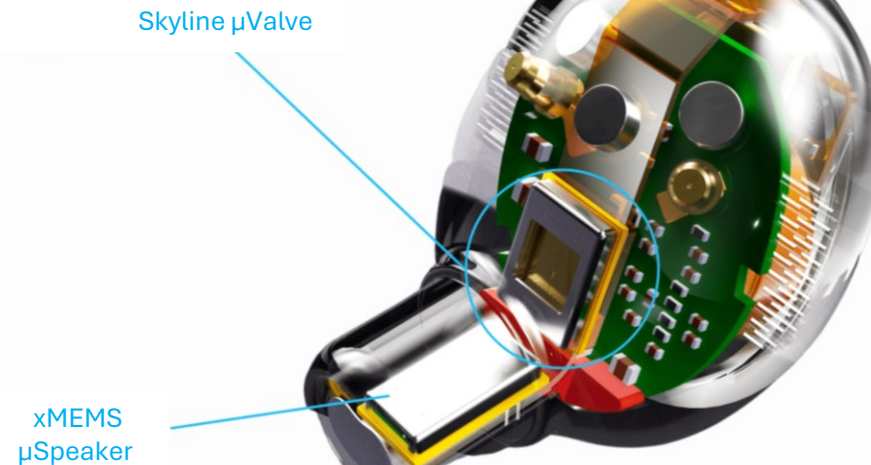
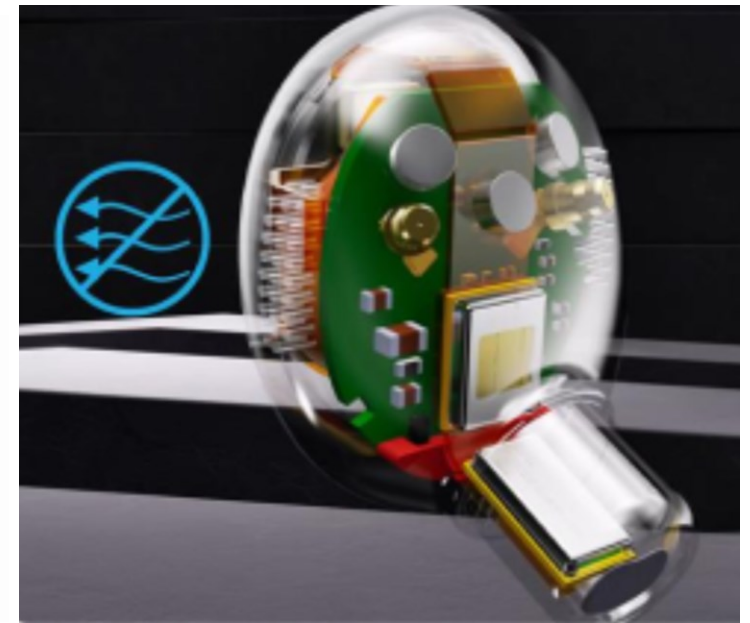

Thank You!

